

PUBLISHED
JULY 13, 1943.
BY A. P. C.

J. MISSET
ADJUSTING DEVICE FOR ROLLING-MILLS
Filed Dec. 30, 1942

Serial No.
470,630
2 Sheets-Sheet 1

Fig.1.

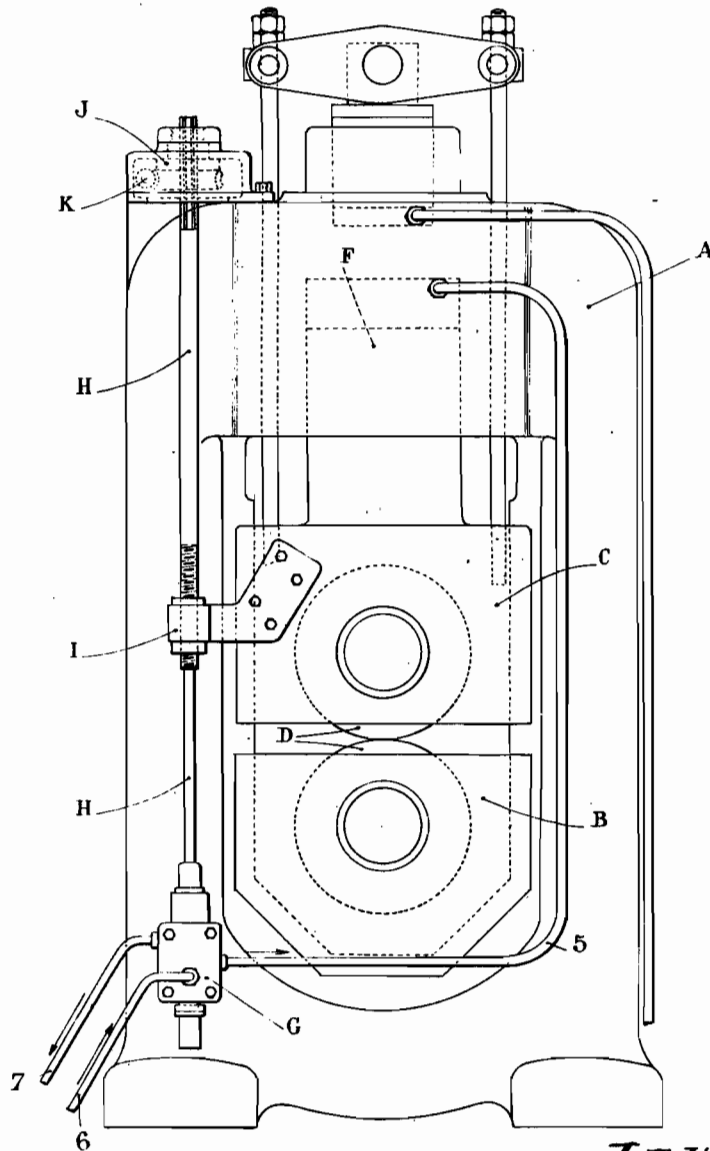

Inventor
J. Misset
By *Glenn K. Downing & Arthur
Attys.*

PUBLISHED

JULY 13, 1943.

BY A. P. C.

J. MISSET

ADJUSTING DEVICE FOR ROLLING-MILLS

Filed Dec. 30, 1942

Serial No.

470,630

2 Sheets-Sheet 2

Fig. 2

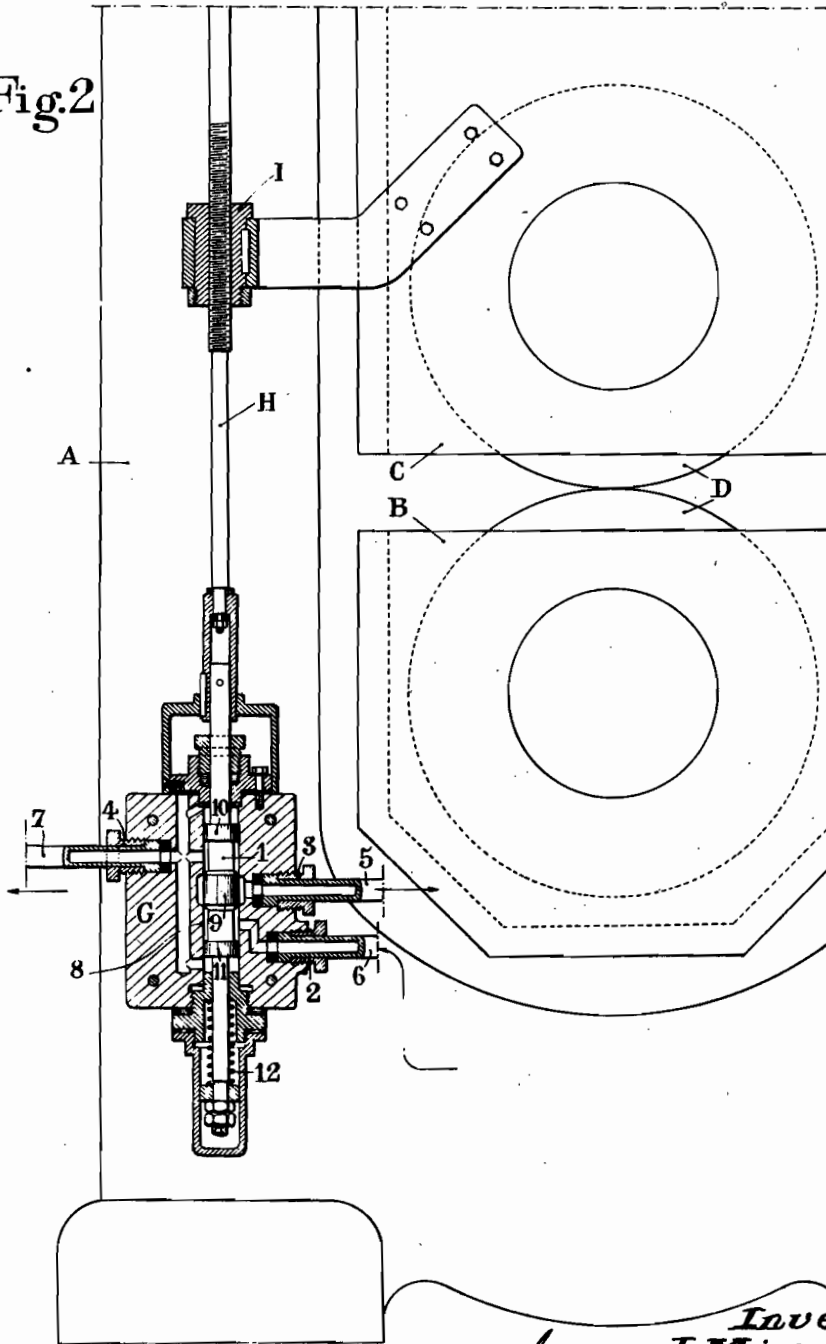

Inventor
J. Misset
By *Grant Downing & Ashbell*
Attys

ALIEN PROPERTY CUSTODIAN

ADJUSTING DEVICE FOR ROLLING-MILLS

Jean Misset, Firminy, France; vested in the Alien Property Custodian

Application filed December 30, 1942

According to known processes, the adjusting of the rolls in rolling-mill housings is obtained by screws or by wedges, operated by hand or mechanically controlled. These devices have serious inconveniences:

1. The taking up of the play and the resilient distortions of the housings determine a "yielding" of a certain importance, which must be made the best of, when introducing the product into the rolling-mill. A certain dubiousness as regards the importance of the reductions in thickness obtained results therefrom, which are not in simple relation with the adjustment effected, and this dubiousness constitutes an inconvenience for obtaining bars or strips rolled to the desired thickness, when it is impossible to measure the thickness of the product as it issues from the housing.

The yielding causes, moreover, unevennesses of thickness in the rolled products, when the resistance to plastic distortion of the metal is not the same at all the points of the length of the rolled bar or strip. Finally, when rolling strips on straight barrel rolls, an important yielding can be the cause of serious difficulties in the rolling.

All these considerations have led rolling-mill constructors to strive to reduce the importance of the yielding, in particular by increasing the cross section of the uprights of the housing, for causing said members to work at a very low working stress, clearly lower than that which could be admitted simply as regards the resistance of the metal. This results in the rolling-mill housings being very heavy, which may lead, in the case of important rolling-mills, to great constructional difficulties.

2. It is impossible in many cases and, more particularly in hot rolling-mills, owing to the friction forces set in action, to tighten or to loosen the rolls in the course of a pass; in particular, the fact that it is impossible to loosen the rolls presents serious inconveniences when an accident occurs during the rolling.

3. The device is cumbersome, and consequently costly; the forces set in action for the adjustment are out of proportion with the result obtained.

Devices in which hydraulic jacks replaced the screws or wedges, have been tried, but they also present inconveniences which have not allowed their use to become general:

1. The yielding of the jacks due to the compressibility of the liquids at high pressures, is added to the normal yielding of the housings and

leads to very high figures, inconsistent with correct rolling.

2. The slightest leakages, difficultly avoidable, produce in the adjustment of both sides of the housing, a lack of balance which cannot be admitted.

The present invention has for object a device according to which the movement for adjusting the rolls is under the dependence of a control system, devised in such a manner as to remedy the above mentioned inconveniences.

This result is obtained by means of a relay, which controls the filling up or the emptying of the adjusting jacks, in such a manner that the yielding is compensated in totality or in part.

The system proposed thus offers the following advantages:

1. Reduction or elimination of the yielding, allowing easier and more accurate rolling, even allowing eventually to automatically obtain a product having a thickness equal to that indicated by the dial of the control apparatus previously adjusted.

2. Possibility of using housings of smaller cross section and weight.

3. Possibility of tightening or loosening the rolls in the course of the pass.

4. Reduced cumbersomeness well clearing the upper part of the housing.

5. Reduction of the energy set in action.

6. To a certain extent, insensitiveness to leakages which may occur in the plant.

The following description applies to the use of a hydraulic control relay, but it is to be understood that the use of an electric or mechanical relay is also included in the scope of the present patent.

Likewise, the use of a hydraulic, electric or mechanical control device for controlling the adjusting device having a screw or a wedge, although it does not allow of remedying all the previously mentioned inconveniences, is also included in the scope of the patent.

In the accompanying drawing, Fig. 1 diagrammatically illustrates, in an embodiment given simply by way of demonstration, a possible form of construction of the device mounted on one of the uprights of a two-high housing; the second upright is equipped in an identical manner and the control shaft disposed with a worm drive K simultaneously actuates both devices (through the medium of a coupling allowing to previously regulate the adjustment on each separate upright).

The upright of the housing A containing the

lower chock B and the upper chock C of the rolls D is equipped with a lifting device E of ordinary type. The adjustment of the upper roll is obtained by means of the hydraulic jack F, the placing under pressure or discharge of which is controlled by the hydraulic relay G, secured to the lower part of the upright of the housing A, and supplied with water under pressure by an accumulator, not shown.

The piston I of the hydraulic relay G is attached to the rod H which can screw in the nut I, rigidly connected to the upper chock C. The rotation of rod H is controlled by the wheel J in which the rod H can slide without rotating. The worm wheel J is actuated by the shaft bearing the screw K, operated for instance by means of a hand-wheel and which simultaneously controls the two identical devices of the housing.

Fig. 2 illustrates a diagrammatic section of the relay G, on an enlarged scale.

The body of the relay G is provided with connections 2, 3, 4 connected by pipes 5, 6, 7 respectively to the accumulator for water under pressure, to the adjusting jack, and to the discharge tank.

These connections are in communication with orifices leading to the cylinder 8 of the relay. The piston I comprises flanges 9, 10, 11 the dimensions of which are so chosen that in median position—that shown in Fig. 2—the jack is neither connected with the pressure supply nor with the discharge, but that a displacement of small amplitude in one direction or in the other puts the jack in communication with the accumulator through 2—6, or with the discharge through 4—7. A spring 12 tends to bring the device in the lower position.

The operation of the device is as follows:

1. Before a rolling pass, the hand-wheel and the shaft K are actuated, for instance in the direction corresponding to tightening. The rod H rises in the nut I and the piston of the relay puts the jack in communication with the accumulator.

The upper roll then approaches the lower roll and actuates the nut I, the screw H and the piston of the relay until the communication is cut off. Everything takes place as if the screw H, acting on the nut I, directly actuated the upper roll, taking a bearing on the relay.

2. During rolling, the relay reacts in the same manner, so as to maintain constant the distance between the relay G and the nut I, that is to say, between the bottom of the housing and the upper chock, thus compensating the "yielding" which results from the resilient distortion of the upright of the housing and from the compressibility of the liquid of the adjusting jack.

3. In case of accident during rolling, it is easy to actuate the hand-wheel for immediately loosening the rolls, as no supplementary stress resulting from rolling can be exerted on the whole of the control device.

The present description has contemplated a possible embodiment of the device in which as application points for the adjustment have been chosen, on the one hand, the lower part of the housing and, on the other hand, the upper chock.

A different embodiment, having other application points and, in particular, the rolls themselves (which allows of also compensating the clearances between rolls and chocks) or even the thickness of the rolled product, is also included in the scope of the invention.

It is pointed out that:

The adaptation of the device to a four-high or other cluster mill.

The fact of controlling by the relay provided, not only the adjusting jack alone, but simultaneously the adjusting jack and the lifting jack.

The fact of controlling the control relay through the medium of an amplifying device increasing the accuracy or sensitiveness of the control,

Are also included in the scope of the present invention.

JEAN MISSET.