

PUBLISHED

MAY 11, 1943.

BY A. P. C.

F. EGERSDÖRFER

GEAR PUMPS

Filed Jan. 31, 1942

Serial No.

429,040

2 Sheets-Sheet 1

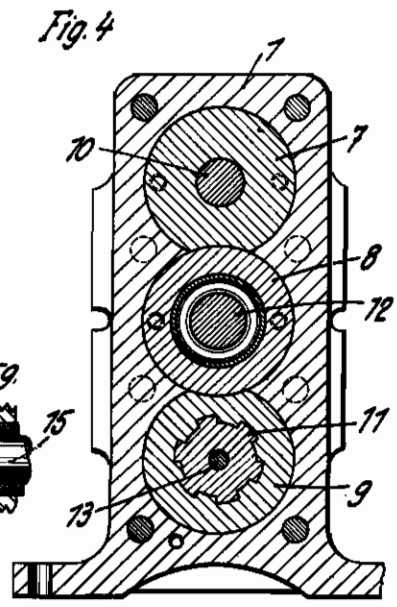
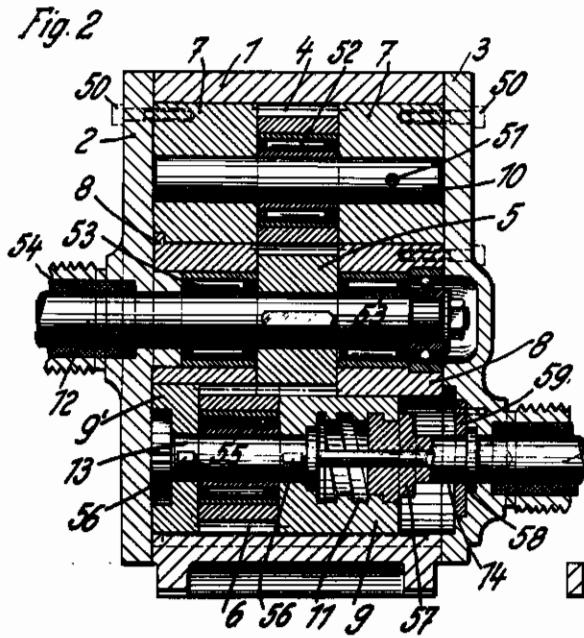
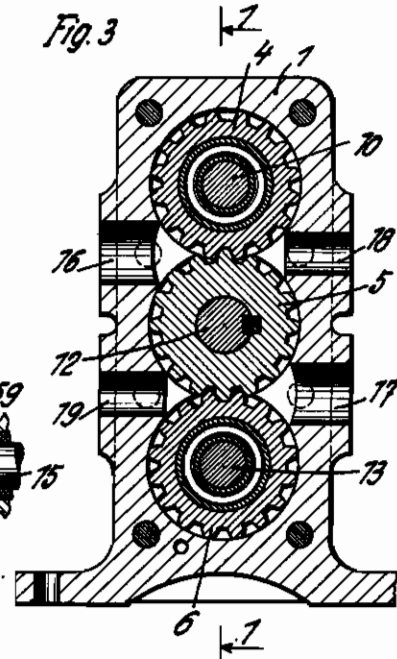
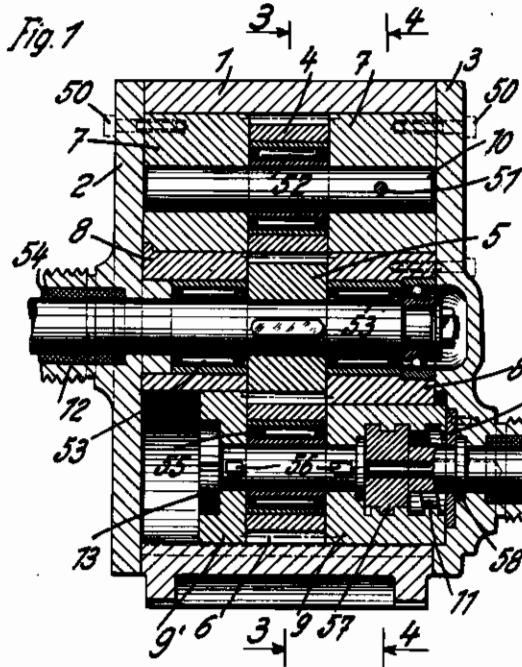

Inventor:
Fritz Egersdorfer
 by *Frank Reinhold*
 Attorney.

PUBLISHED
MAY 11, 1943.
BY A. P. C.

F. EGERSDÖRFER
GEAR PUMPS
Filed Jan. 31, 1942

Serial No.
429,040
2 Sheets—Sheet 2

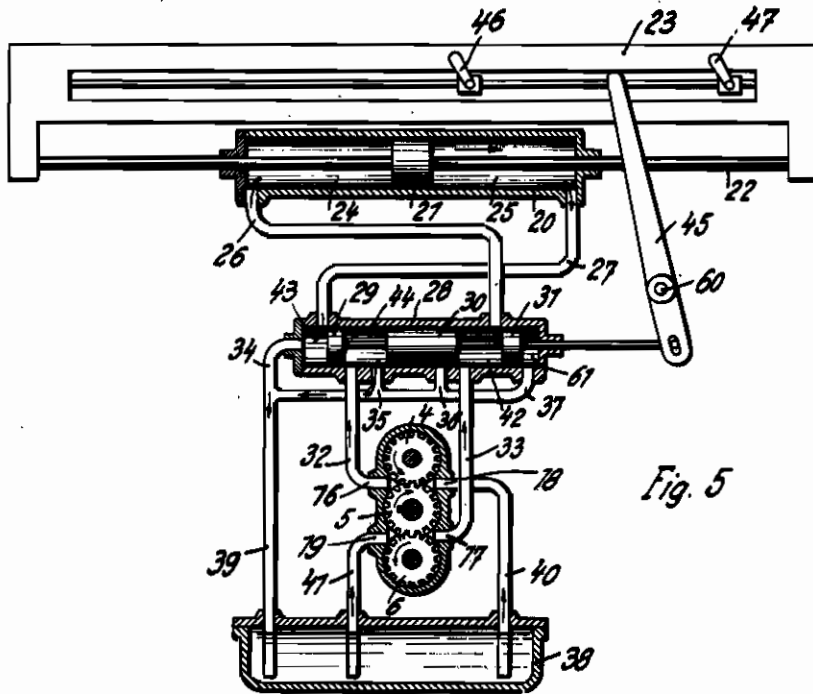

Fig. 5

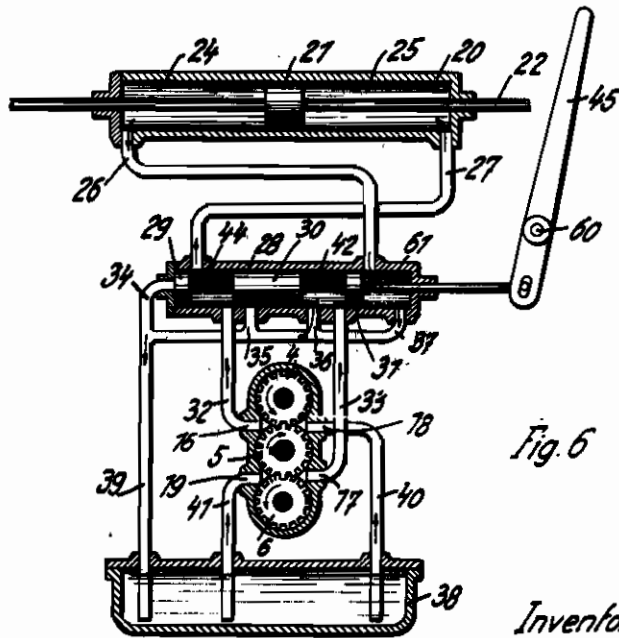

Fig. 6

Inventor:
Fritz Eggersdorfer
by *Franz Reichstein*
Attorney.

ALIEN PROPERTY CUSTODIAN

GEAR PUMPS

Fritz Egersdörfer, Berlin, Germany; vested in the
Allen Property Custodian

Application filed January 31, 1942

My invention relates to improvements in gear pumps, and more particularly in gear pumps of the type comprising three interengaging gear wheels arranged in a casing provided with suction and pressure passages, the inner gear wheel cooperating with the outer gear wheels to provide two pumps. The object of the improvements is to provide a pump of this type in which the capacity of one pump may be varied, while the capacity of the other pump remains constant. With this object in view my invention consists in mounting one of the outer gear wheels so as to be shiftable in axial direction for varying the interengaging portions of the length of the teeth of said outer gear wheel and the inner gear wheel, bushings being provided at opposite sides of the said shiftable outer gear wheel and movable therewith. Pumps of this type may be used for supplying pressure fluid to a hydraulic mechanism designed for use in connection with certain machine tools such as shaping machines and horizontal and vertical planing machines in which the velocity of the working stroke is to be regulated while the return stroke has uniform movement.

For the purpose of explaining the invention an example embodying the same has been shown in the accompanying drawings in which the same reference characters have been used in all the views to indicate corresponding parts. In said drawings

Fig. 1 is a sectional elevation taken on the line 1-1 of Fig. 3 and showing the gear pump, the gear wheels of both pumps being in the position for conveying the maximum of the fluid,

Fig. 2 is a similar sectional elevation showing one of the pumps set to reduced feeding capacity,

Fig. 3 is a sectional elevation taken on the line 3-3 of Fig. 1,

Fig. 4 is a sectional elevation taken on the line 4-4 of Fig. 1,

Figs. 5 and 6 are somewhat diagrammatical elevations partly in section showing the hydraulic mechanism including the pumps, the valve controlling the supply of the pressure fluid, and the cylinder and piston by which reciprocating movement is transmitted to the machine tool or the like.

In describing the invention the gear pump will be described in connection with a hydraulic mechanism for imparting reciprocating movement to the slide of a machine tool. The pump has been shown in detail in Figs. 1 to 4. It comprises a casing 1 closed at its ends by heads 2 and 3, and three gear wheels 4, 5 and 6 mounted respec-

tively between bushings 7, 7 and 8, 8 and 8, 8'. The bushings 7 and 8 are fixed to the heads 2 and 3, for example by means of screws 50, and the lower bushings 8, 8' are axially shiftable but not rotatable within the casing 1, the bushing 8' being reduced in length to permit such axial displacement. The upper gear wheel 4 is rotatably mounted on a stationary shaft 10 mounted in the bushings 7, 7 and fixed thereto by means of a pin 51. The gear wheel 4 is mounted on the said shaft 10 by means of an anti-friction bearing 52. The gear wheel 5 is keyed to a shaft 12 rotatably mounted in the bushings 8 by means of anti-friction bearings 53 and passed through a stuffing box 54 provided in the end wall 2, the said shaft being connected to the main driving shaft of the machine tool or the like for being rotated thereby at uniform velocity. The gear wheel 6 is rotatably mounted by means of an anti-friction bearing 55 on a shaft 13 secured to the bushings 8 and 8' by means of keys 56. The shaft 13 is connected with a stem 15 rotatably mounted in the head 3 and formed at its inner end with a head 57 having external screw threads and engaging in internal screw threads of a cylindrical socket 11 made in the bushing 8. The said stem 15 is formed with a collar 58 held in position between the head 3 and a washer 59. Thus, when the stem 15 is rotated the bushing 8, the shaft 13, the bushing 8' and the gear wheel 6 are shifted in axial direction. By shifting the gear wheel to the left, for example into the position shown in Fig. 2, the capacity of the spaces included between the teeth of the gear wheels 5 and 6 and therefore the volume of pressure fluid supplied by the pump are reduced.

In the casing of the machine a pressure passage 16 and a suction passage 16 for the pump comprising the gear wheels 4 and 5 and a pressure passage 17 and a suction passage 18 for the pump provided by the gear wheels 5 and 6 are provided, the said suction and pressure passages being adapted to be connected to suction and pressure conduits, as will be described hereafter. It will be understood that the upper pump 4, 5 always conveys the same amount of pressure fluid, while the amount of pressure fluid supplied by the pump 5, 6 is variable and dependent upon the axial adjustment of the gear wheel 6.

As is shown in Figs. 5 and 6 the pump thus described is used in a hydraulic mechanism for producing reciprocating movement, which is connected for example to a planing machine (not shown). The mechanism has been illustrated in Figs. 5 and 6. The pump is connected with a

controlling valve, comprising a cylinder 28 having three cylindrical slide valves 29, 30 and 31 shiftable therein, the said slide valves being connected with each other and with a lever 45 rockingly mounted at 80. The slide valve is connected by pipes 26 and 27 with the opposite ends of a cylinder 20 in which a piston 21 has reciprocating movement. The piston rod 22 of the said piston is connected with a head 23. By the said slide valves the cylinder 28 is divided into four chambers which are connected with the suction and pressure passages of the pump. The pressure passages 18 and 17 of the pumps are connected by pipes 32 and 33 respectively to the chambers 44 and 42 provided between the slide valves 29 and 30 and 30 and 31. The suction passages 19 and 19 are connected by pipes 40 and 41 with a tank 38 containing the pressure liquid. The said tank is further connected by a pipe 39 and branch pipes 34, 36 and 37 with suitable parts of the valve casing 28.

In the position of the slide valves 29, 30 and 31 shown in Fig. 5 pressure fluid is supplied to the cylinder 20 from the lower pump 5, 6 and through the pipe 33, the chamber 42, and the pipe 26 in a direction for transmitting feeding movement to the planing machine. The volume of pressure liquid supplied by the said pump to the chamber 24 of the cylinder 20, and therefore the velocity of the feeding movement depends on the position of the gear wheel 6. The liquid is forced

from the chamber 25 through the pipe 27 and the chamber 43 to the pipes 34, 36 and the tank 38. While the lower pump thus transmits feeding movement the upper pump runs idle, the liquid delivered therefrom through the pipe 32 being immediately returned through the pipes 35 and 39 to the tank 38. It will thus be apparent that the velocity of the feed may be regulated by shifting the gear wheel 6.

For returning the feeding mechanism the slide valve 29, 30, 31 is set into the position shown in Fig. 6. Now the lower pump runs idle, the liquid delivered therefrom and through the pipe 33 immediately returning through the pipes 36 and 39 into the tank 38. The pressure fluid of the upper pump flows through the pipe 32, the chamber 44 and the pipe 27 into the right hand chamber 25 of the cylinder 20, so that the piston 21 and the parts connected therewith are shifted to the left. The fluid contained within the chamber 24 is returned to the tank 38 through the pipe 26, the chamber 61 and the pipes 37 and 39. It will be understood that the velocity of the return movement is always the same and that it is independent of the position of the gear wheel 6.

The slide valve 29, 30, 31 is operated by means of the lever 45 which is adapted to be engaged by stops 46 and 47 provided on the head 23, the said stops being set so that the valve is reversed at the ends of the strokes.

FRITZ EGERSDÖRFER.