

PUBLISHED
MAY 11, 1943.
BY A. P. C.

T. KOVACS
FOUNTAIN PEN
Filed Nov. 29, 1941

Serial No.
421,061

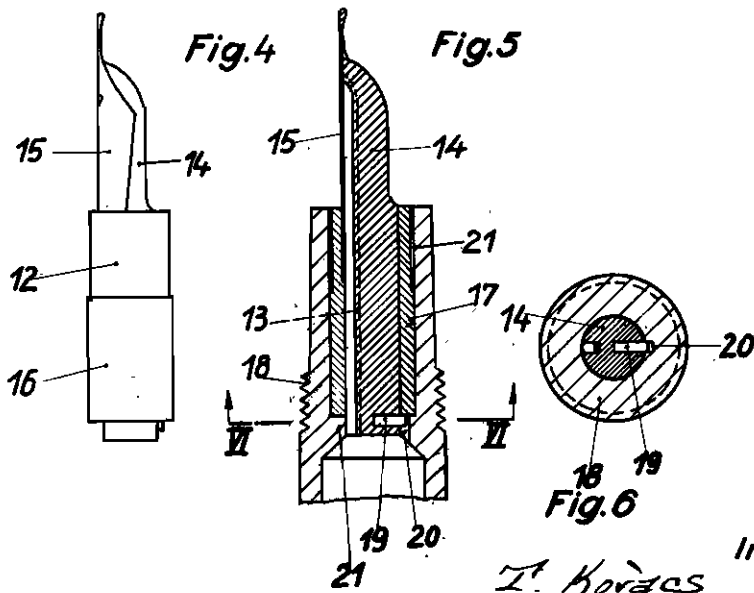
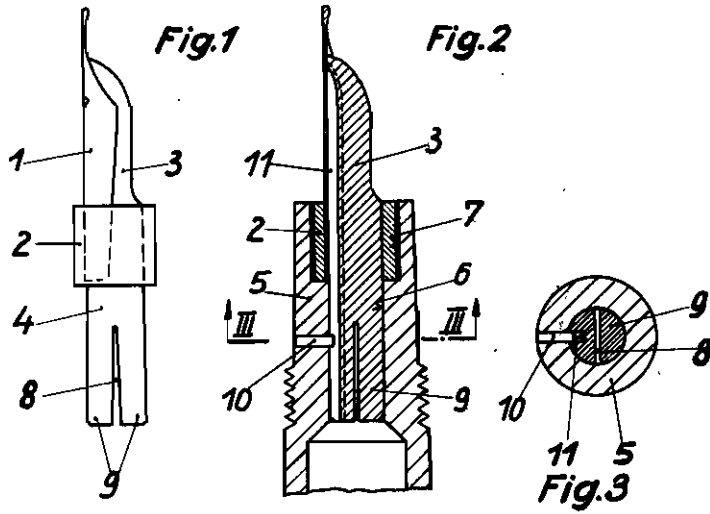

Inventor,
T. Kovacs
By:
Glascop Downing & Co.
Attorneys.

ALIEN PROPERTY CUSTODIAN

FOUNTAIN PEN

Theodor Kovacs, Wien 117, Germany; vested in
the Alien Property Custodian

Application filed November 29, 1941

This invention relates to a fountain pen equipped with a "unit" adapted to be shoved into the bore of the front portion of the body of the pen holder and comprising the pen writing proper, the ink conducting and supplying member and a sleeve. With the known fountain pens of this type having a box arranged in the front portion of the holder—arranging the part of the box surrounding the pen outside the holder renders the packing or tightening difficult—the box fits accurately into the conical or cylindrical bore of the front portion of the holder and serves for holding said "unit" in place. Deformations of the sleeve by reason of tensions arising in the pen can cause jamming of the "unit" in the front portion of holders of the type mentioned which may entail damages at the pen holder in general and the pen proper in particular.

The above-mentioned drawbacks are overcome, according to the present invention, by the improvement that the outer diameter of the sleeve is made smaller than the diameter of the bore receiving it and serves for holding fast the rear portion of the ink conducting and supplying member which extends through and beyond it. Owing to that smaller diameter of the sleeve relatively to the bore into which it is inserted jamming of the "unit" in the front portion of the holder body is resurely and reliably prevented. The rear portion of the ink member extending beyond said sleeve can fit into the cylindrical bore of the body in such a manner as to be shiftable therein whereby the possibility is afforded that the "unit" can always be easily exchanged. It is also possible to provide for an additional clamping action by providing a longitudinal slot in the inner end of the ink member and bending the thus separated two ink member portions slightly asunder so that they constitute elastic portions able to exert a certain slight clamping action.

In a modified constructional form of the thus improved fountain pen the sleeve may extend over and beyond the ink member, that extension fitting then closely into the bore of the holder body whereby the ink body is securely retained therein.

In order to prevent the "unit" from turning in the holder body the front portion thereof may be provided with a transverse pin engaging a groove, which may be the air groove of the ink member, or said pin may be provided in this member in this member and engaging a groove of said front portion, all as fully described hereinafter.

The invention is illustrated diagrammatically and by way of example on the accompanying drawing on which Figure 1 is a side-view of the "unit" composed of the pen proper, the ink conducting and supplying member and the sleeve. Figure 2 shows an axial section through these members, in connection with the front portion of the body of the holder. Figure 3 is a transverse section through the members shown in Fig. 2 in the line III—III, and seen in the direction indicated by the arrows, and the Figures 4, 5 and 6 show views corresponding to the Figs. 1-3 and relate to a modified constructional form of the improved fountain pen.

Referring to the constructional form shown in Figs. 1-3 the "unit" mentioned in the introduction of this specification consists of the pen proper 1, the sleeve 2 and the ink conducting and supplying member 3. In the front portion 5 of the body of the holder is a suitably narrow bore 5 serving for the reception of that portion 4 of the ink conducting and supplying member 3 which extends from the sleeve 2 into said front portion 5 of the body. The sleeve 2 is situated in a suitably larger bore of said body portion 5. The part 4 fits into the part 5 in such a manner as to be shiftable therein, and the sleeve 7 fits into the bore provided for it with a certain play. In the part 4 is a longitudinal slot 8 and the ends thereby formed are slightly bent asunder so as to be able to exert an elastic action and there is, furthermore, in said part 4 a transverse pin 10 engaging with its inner end a longitudinal air passage 11 provided in the ink conducting and supplying member 3.

The manner of operation of the fountain pen is as follows:

Owing to the elasticity of the pen which is pressed against the ink supplying member 3 by means of the sleeve 2 this latter will be deformed in the course of time, but the gap left in the bore 7 is large enough to allow of even a large deformation of the sleeve without entailing jamming thereof, whereby an easy exchangeability of the "unit" is warranted. The part 4 is not subject to deformations and can, therefore, fit into the bore 6 of the body in such a manner as to be comparatively easily shiftable therein. In the whole the "unit" is reliably seated and tightened in the holder body. The elasticity of the ink member 3 at its inner end permits of a somewhat slighter accuracy of the seat thereof in the holder body. The pin 10 engaging the air passage 11 prevents the "unit" from turning in the body.

In the modification shown in Figs. 4-6 the sleeve 12 extends nearly over the entire lower

portion 13 of the ink member 14. Where the sleeve embraces the inner portion of the pen 15, there it is tapered relatively to its other portion 16, this portion fitting more accurately into the cylindrical bore of the front part of the holder body, but being, nevertheless, shiftable therein, so that the "unit" is guided, but also held in its proper operative position. There is also with this modified constructional form a gap between the free end portion of the sleeve 12 and the surrounding end portion of the holder body, where there

is the inner end of the pin, and thus jamming of the "unit" within the bore of the body owing to a deformation of the sleeve securely and reliably prevented.

5 In order to prevent the "unit" from turning a pin 19 is inserted into the ink member 14 and engages with its outwardly projecting end a groove 20 provided in an inner shoulder 21 of the holder body, this shoulder forming an abutment
10 for the sleeve 16, as shown in Fig. 5.

THEODOR KOVÁCS.