

PUBLISHED
 JUNE 1, 1943.
 BY A. P. C.

L. L. DE KRAMOLIN
 DEVICES FOR REGULATING RADIO
 SETS AND THE LIKE
 Filed March 4, 1940

Serial No.
 322,193

7 Sheets-Sheet 1

Fig. 1.

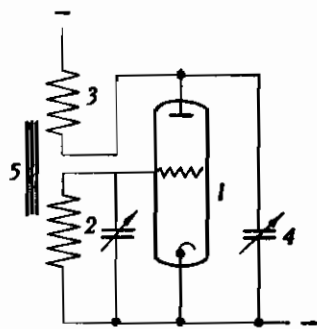

Fig. 2.

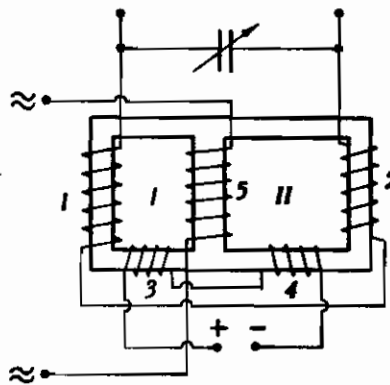

Fig. 3.

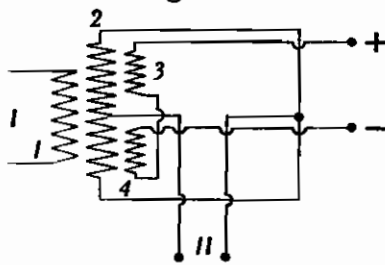
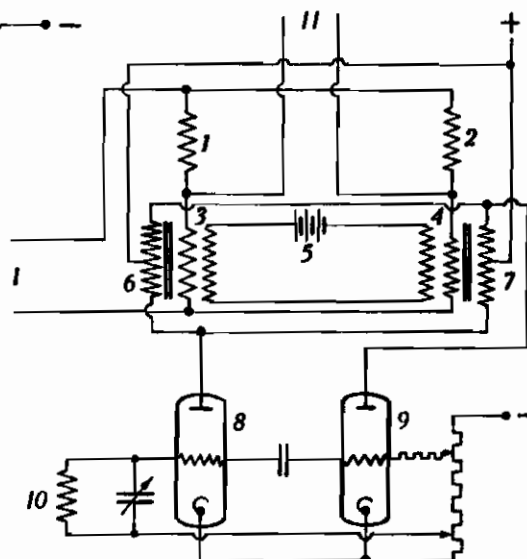

Fig. 4.



Inventor

L. L. De Kramolin

by

Young, Emery & Glasgow
 Attorneys

PUBLISHED
JUNE 1, 1943.
BY A. P. G.

L. L. DE KRAMOLIN
DEVICES FOR REGULATING RADIO
SETS AND THE LIKE
Filed March 4, 1940

Serial No.
322,193

7 Sheets-Sheet 2

Fig. 7.

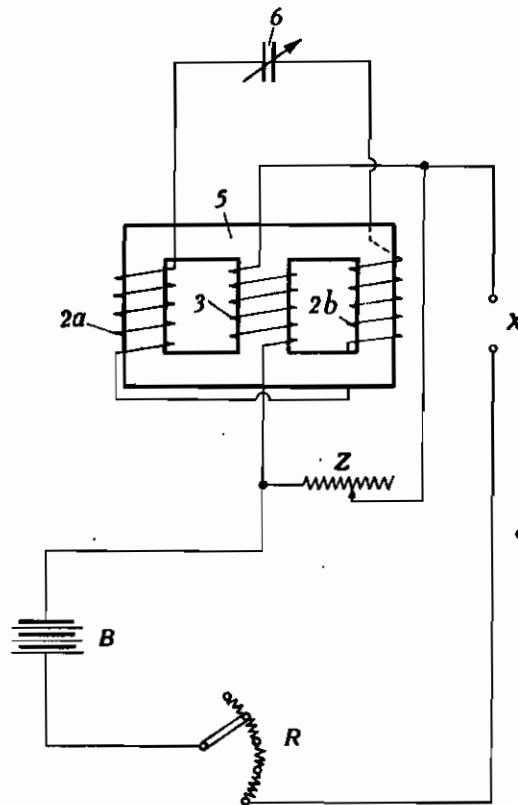

Fig. 5.

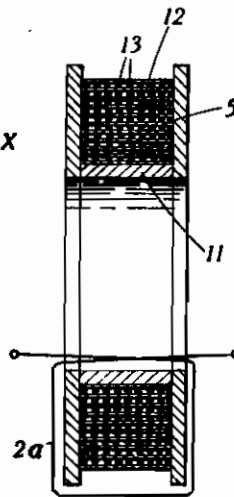
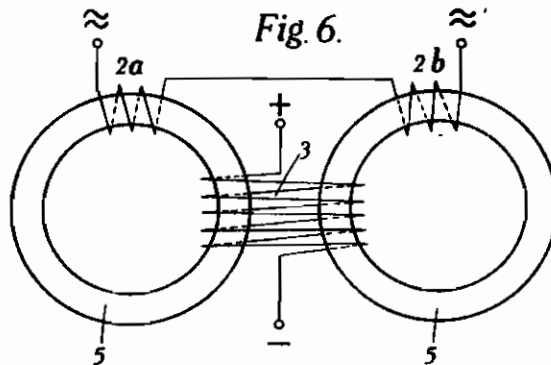

Fig. 6.



Inventor

L. L. De Kramolin
by

Young, Emery & Thompson
Attorneys

PUBLISHED
 JUNE 1, 1943.
 BY A. P. C.

L. L. DE KRAMOLIN
 DEVICES FOR REGULATING RADIO
 SETS AND THE LIKE
 Filed March 4, 1940

Serial No.
 322,193

7 Sheets-Sheet 3

Fig 8.

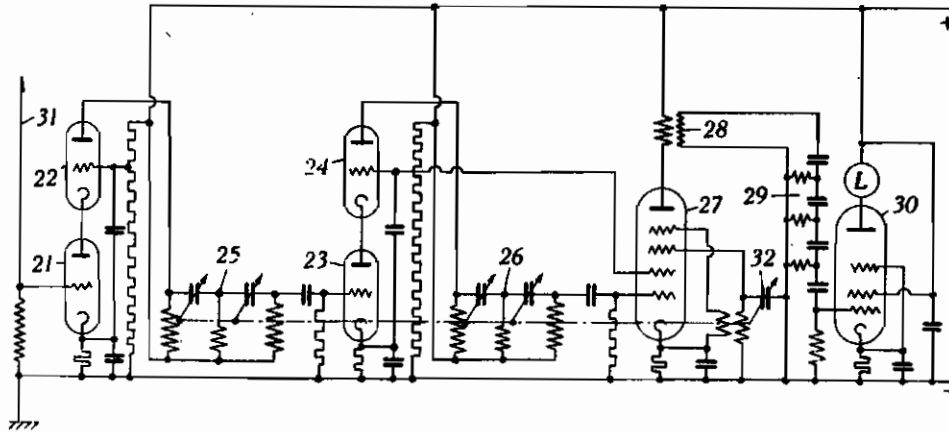

Fig 9.

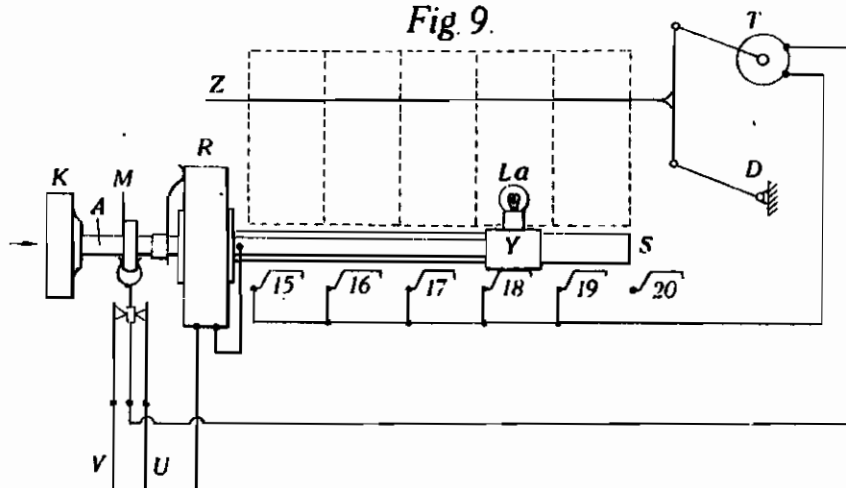
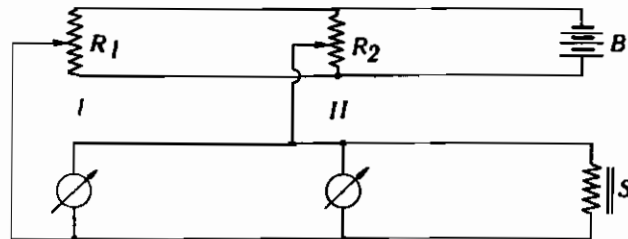

Fig 10.



Inventor

L. L. De Kramolin

by

Young, Emery & Thompson
 Attorneys

PUBLISHED

JUNE 1, 1943.

BY A. P. C.

L. L. DE KRAMOLIN
DEVICES FOR REGULATING RADIO
SETS AND THE LIKE
Filed March 4, 1940

Serial No.

322,193

7 Sheets-Sheet 4

Fig. 11.

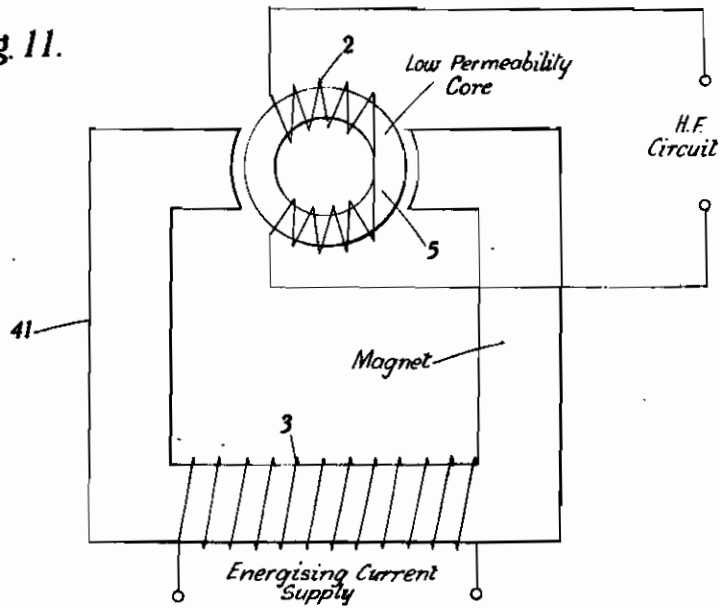
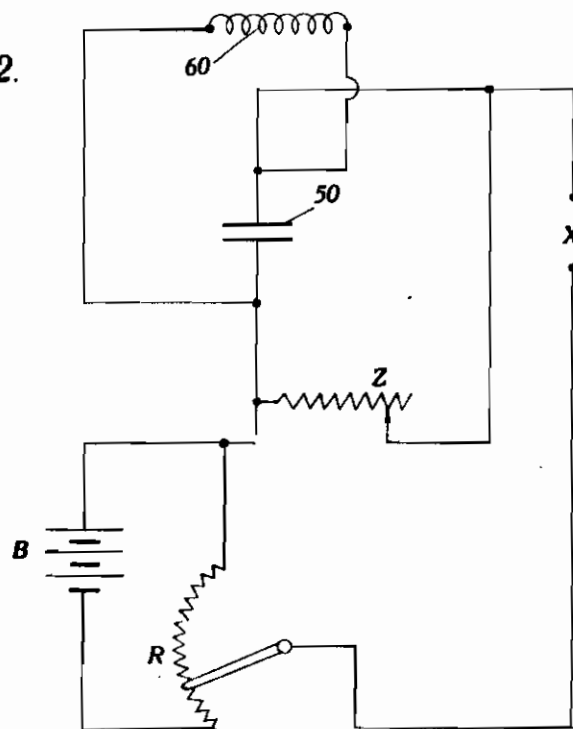

Fig. 12.



Inventor
L. L. De Kramolin
by
Young, Emery & Hopson
Attorneys

PUBLISHED
JUNE 1, 1943.
BY A. P. C.

L. L. DE KRAMOLIN
DEVICES FOR REGULATING RADIO
SETS AND THE LIKE
Filed March 4, 1940

Serial No.
322,193
7 Sheets-Sheet 5

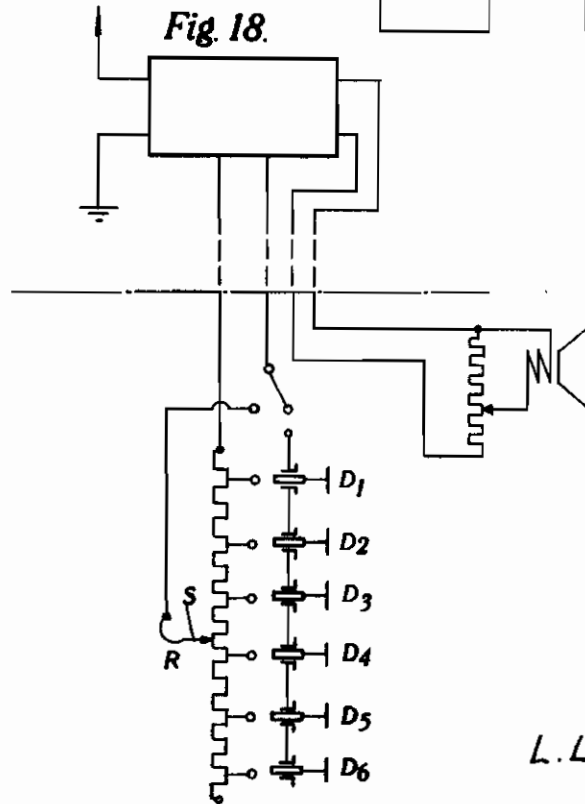
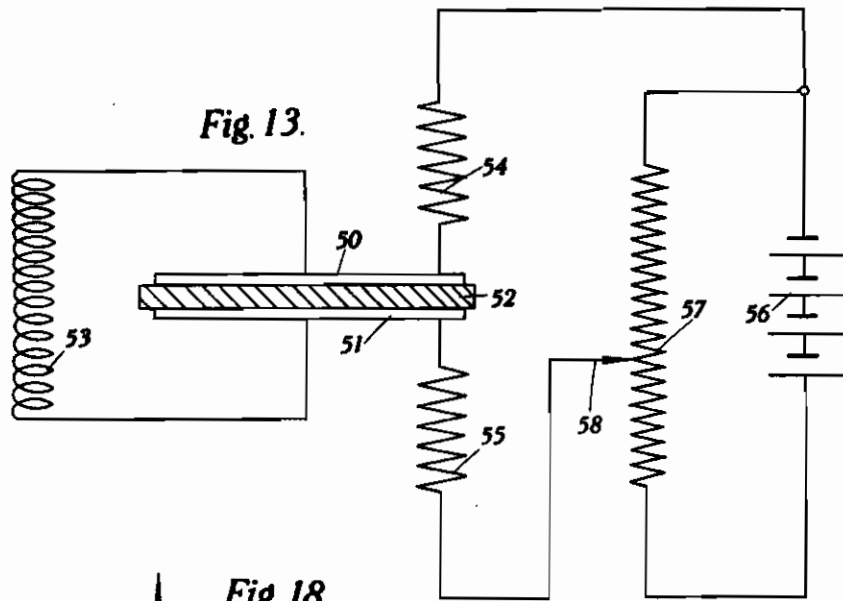

Inventor
L. L. De Kramolin
by
Young, Enay & Hays
Attorney

PUBLISHED
 JUNE 1, 1943.
 BY A. P. C.

L. L. DE KRAMOLIN
 DEVICES FOR REGULATING RADIO
 SETS AND THE LIKE
 Filed March 4, 1940

Serial No.
 322,193

7 Sheets-Sheet 6

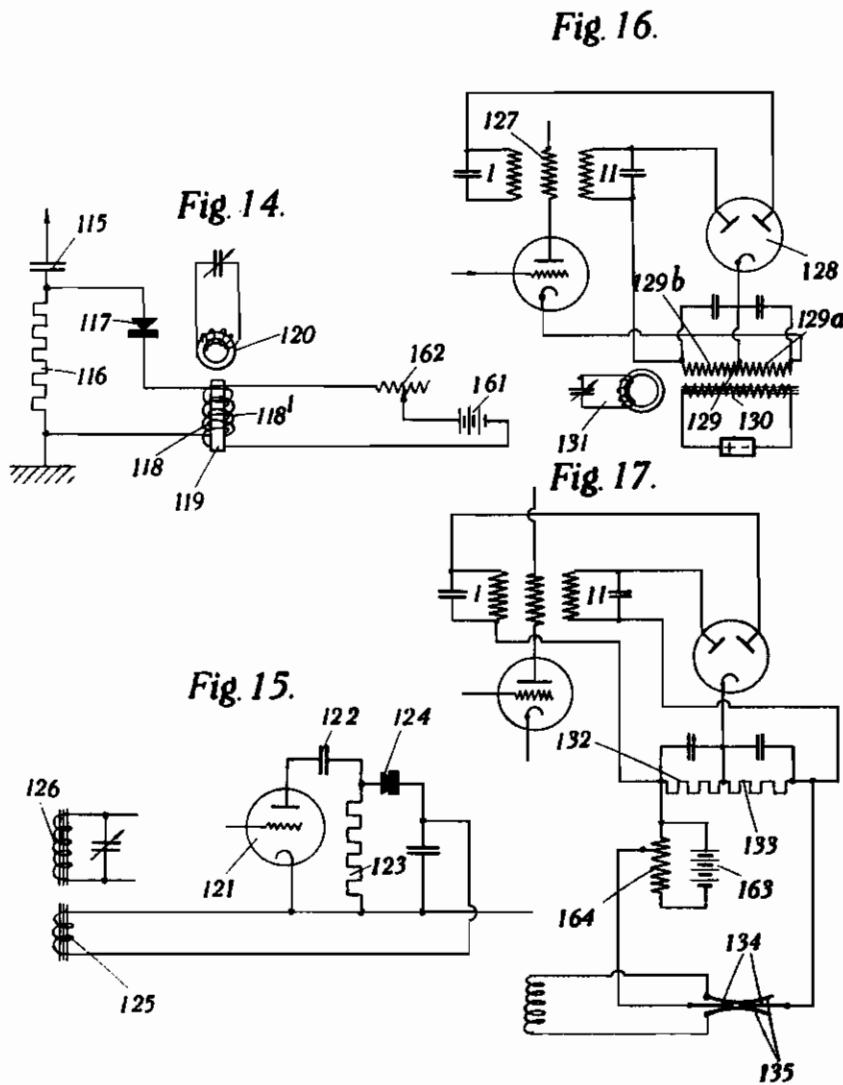

Inventor
 L. L. De Kramolin
 by
 Young, Emery & Thompson
 Attorney

PUBLISHED
 JUNE 1, 1943.
 BY A. P. C.

L. L. DE KRAMOLIN
 DEVICES FOR REGULATING RADIO
 SETS AND THE LIKE
 Filed March 4, 1940

Serial No.
 322,193

7 Sheets—Sheet 7

Fig. 19.

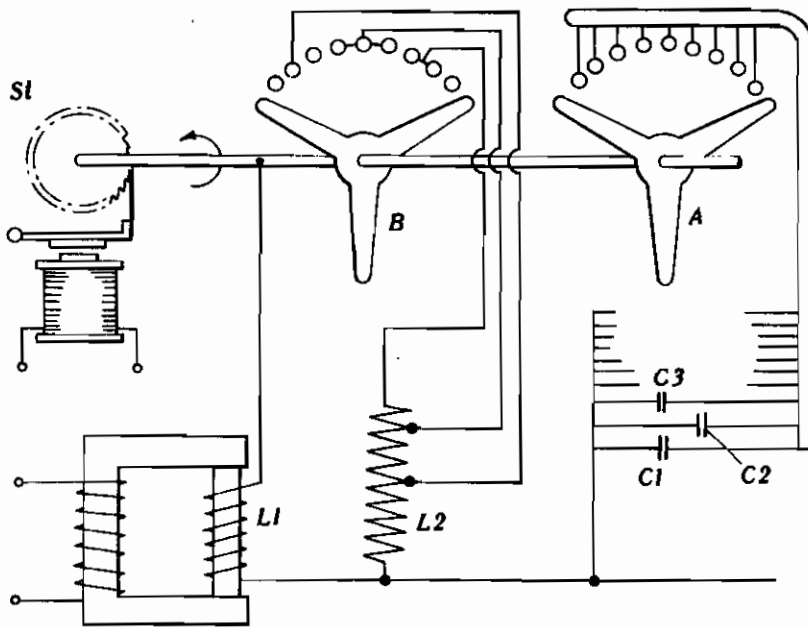
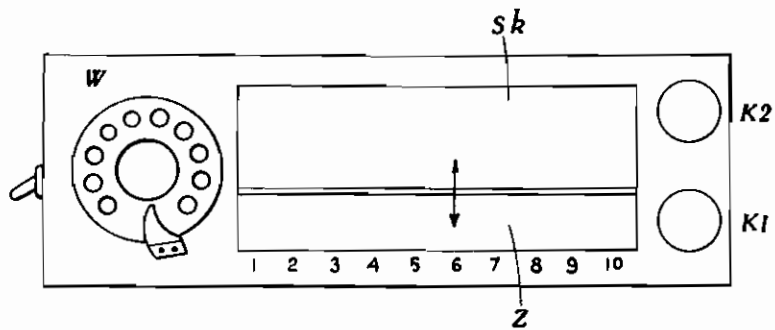

Fig. 20.



Inventor

L. L. De Kramolin
 by

Young, Enay & Thompson
 Attorneys

ALIEN PROPERTY CUSTODIAN

DEVICES FOR REGULATING RADIO SETS AND THE LIKE

Leon Ladislas de Kramolin, Berlin-Kladow, Ger-
many; vested in the Alien Property Custodian

Application filed March 4, 1940

My invention relates particularly to a method of regulating radio receiving sets and the like by means of inductance variations in iron cores.

As is well-known, with sufficiently fine subdivision of suitable types of iron alloys, it is possible to provide high-frequency coils with magnetic cores. If the cores are made displaceable within the coils tuning can be effected by such displacement in a manner well-known per se. This variation of inductance, however, can also be obtained in a different manner, e. g. by varying the preliminary magnetisation of the core by means of a direct current. Such a method of varying the inductance offers a large number of possibilities of utilization, one very interesting instance of which comprises the provision of an automatic volume control.

In the simplest case, such an apparatus works as follows: An oscillatory circuit, tuned in some manner to the wave to be received is provided, the oscillations of which are applied to an audion. In the oscillatory circuit, a part or the whole of the inductance is arranged on a coil of ferromagnetic-material e. g. Ferrocart. In the anode circuit of the audion, there is provided a simple filtering means, which separates the direct current component of the anode current from the alternating current component. The alternating current component (modulation frequency) is supplied to the consumer, that is, a telephone or a further amplifier, and the direct current component is led through a second winding on the ferromagnetic core of the tuning coil.

On increase of the audion current or decrease of the audion current (according as to whether grid or anode current rectification is employed), the result can then be obtained that, if normal volume is employed, the coil is just tuned to the oscillation to be received. If the volume increases beyond an agreeable extent, then (assuming that working is being effected with the detector tube at the lower bend) an increase of the anode current causes a decrease in the inductance of the coil, which de-tunes the receiving oscillatory circuit to such an extent that an agreeable volume is just restored. It is seen that a simple volume control device can be assembled in this manner. In this case it is possible, not only to decrease the volume if the reception is too powerful, but also, quite simply if the volume is insufficient, in which case the disturbance level would be too high in proportion, to obtain a decrease of volume. For this purpose, it is only necessary to balance the tuning accurately at a mean value of the volume. If the volume falls below this value, then by weakening the direct current component of the anode current of the detector tube, an increase of the inductance and this de-tuning will occur, while with excessive volume or field strength of the receiver oscillation at the receiving station,

the self-inductance becomes too small. In normal automatic volume control arrangements there often exists an undesirable relationship between the time constant of the regulating circuit and the regulating quality or other characteristics of the regulator. With the present construction and also in all other possibilities discussed here, however, it is possible regardless of the time constant, to suppress any other action between the regulating and regulated circuit by entirely decoupling the regulating circuit from the regulated circuit, e. g. by use well-known per se of a three-limb transformer or the like. If due to small asymmetries in the masses of the limbs or in the coil configuration, there should be no complete decoupling at the outset, then a subsequent correction can be obtained either by displacement of individual convolutions or groups of convolutions or by readjusting the core by a slight subsequent deformation, say, by cutting off small particles or by deformation by pressure, which is quite possible in view of the relatively soft consistency of such cores.

Should the presence of a sharp resonance curve cause an excessive instability in the volume, any desired flattening of the regulating curve may be produced by increasing the damping of the circuit. It is also possible by the use of chain conductors to deform the resonance curve in such a manner that the desired regulating characteristic is provided. In order that the selectivity of the reception may not be impaired by such measures, individual invariable, more or less sharply tuned, circuits may be employed for the actual receiving selection and these circuits coupled to the detector tube by circuit variable in its tuning in accordance with the volume in the manner hereinbefore described. Of course, any desired number of high-frequency amplifying stages may also be connected in series with the detector tube, which stages may be influenced by the receiving field strength in a similar manner as has been herein described for a detector. The greater number of stages in which the influencing is effected, the greater of course is the effect. In order to avoid, particularly in the case of a number of circuits, displacing the resonance position of the whole receiving system within the frequency spectrum in accordance with the volume, it may be preferable in two successive circuits or else within a single circuit by reversal of the direction of current in the preliminary magnetisation windings on occurrence of the regulating action, to displace the resonance position of the part-circuits of a system in the opposite direction in the frequency spectrum, so that the resultant resonance position remains unchanged. Since the regulating circuit is decoupled in relation to the regulated circuits, the same regulating current in series-connection or parallel-con-

nection may traverse the regulating windings of the transformers of a larger number of series-connected amplifier stages without any tendency of the successive amplifier stages to oscillate, arising. To this end, exact decoupling is alone essential, and this can be ensured by any means well-known per se. In order also to prevent capacitive back-couplings through the regulating line, it is preferable to provide for good direct earthing or earthing effected through adequate capacities. However, as is hereinafter shown, volume control is not only obtainable by means of de-tuning. A very simple alternative for instance, comprises automatically regulating the back-coupling, the back-coupling being effected through one of the aforementioned ferromagnetic mass cores or the like.

Other regulating actions can also be obtained in accordance with the invention: Thus, for instance, it is well-known that with only weak reproduction an apparent displacement of the deep sounds occurs. Since, variation of the preliminary magnetisation causes variation of the inductance it is possible with low-frequency transformers or low-frequency sound monitoring arrangements, by means of filters etc. to ensure that the constants of these constructional elements automatically vary in such a manner that the percentage of deep sounds is increased or reduced as desired in relation to the percentage of high sounds, so that with changes of volume, effected for instance, by a manual regulator, provided, in addition to the automatic regulator, the inductance of the low-frequency transformers of the low-frequency chokes or any kinds of smoothing members are so varied that in addition to the automatic or non-automatic volume control, a variation of the timbre automatically occurs in accordance with a pre-determined law. The means for this purpose are no doubt known. If it is desired to obtain an increase in the percentage of deep sounds, then, for instance, in low-frequency transformers, the result will be obtained that due to the reduction of the general volume and due to the preliminary magnetisation reduced thereby, in a corresponding winding, the inductance of the transformer increases whereby, as is well-known, the transmission of deep sounds is also favoured and vice-versa. If an increase in the anode direct current, or other current component employed for preliminary magnetisation, is to produce an increase instead of a decrease in the inductance, then this can be done simply by providing a constant preliminary magnetisation by means of a constant direct current or permanent magnet in addition to the variable magnetisation, in such a manner that the variable and fixed preliminary magnetisations act in opposition to one other. As the variable magnetisation diminishes, the fixed predetermined preliminary magnetisation is then no longer counter-balanced and hence comes into action.

In addition to the methods of automatic volume control and automatic tone control already discussed, it is possible according to the invention to effect tuning of an apparatus quite advantageously, not for the purpose of volume variation, but for the purpose of adjustment to different transmitters. Since it is possible to tune oscillatory circuits merely by varying the direct current intensity of the preliminary magnetisation, this provides, for instance, a method of adjusting a receiver which may be carried out with a very small number of mechanical parts. Since a tuning coil having a Ferrocarril or a similar core, and

a blocking condenser connected in parallel therewith occupy an extremely small space, a variable tunable oscillatory circuit can in this case be arranged in an extremely small space. The space which this oscillatory circuit requires is so small that it can even be arranged in the base of an electron tube or valve. The variation of the tuning can, in this case, be effected in an extremely simple manner, since it is only necessary to provide on the coil an additional direct current winding so dimensioned that, with a core of given mass, it allows sufficient variation of the preliminary magnetisation. Since therefore, there need no longer be any direct mechanical contact between the oscillatory circuit to be adjusted and the tuning means, this method provides an ideal solution for the remote control of receivers. For the operator to tune the oscillatory circuit from any desired distance away, it is only necessary for him to vary the magnetisation by means of a variable resistance or the like for instance a rotary resistance or else a carbon compression resistance which, as is well-known, allows a smooth variation of resistance. This manner of varying inductance is very favorable also for the arrangement of tuned oscillatory circuit at place where a variation of tuning can be mechanically effected only with difficulty, such as for instance, within the vacuum space of an electron tube, since the oscillatory circuit constants are varied without mechanical means. This method of tune is particularly favourable in high-frequency amplifiers which work, for instance, with a choke-coil coupling. In such amplifiers, it is preferable, in order to reduce stray capacity to arrange the coupling choke coil in the interior space of the tube. Thus, for instance, in multiple tubes containing several systems coupled together, the coupling choke may be arranged with the tube in which case the wave band to be transmitted can be displaced at will from outside, simply by varying the preliminary magnetisation. However, the method is also useful for the tuning of ordinary series high-frequency amplifiers.

As has already been shown, when using three-limb transformers or similar arrangements which prevent coupling between the tuned and the tuning circuit, it is possible to remove any danger of mutual coupling taking place between amplifier stages when several amplifier stages are simultaneously tuned by connecting the preliminary magnetisation windings of all the amplifier stages in series or in parallel. In this manner therefore, it is easily possible to construct a set with single-knob manipulation. In order that variations of the preliminary magnetisation may act uniformly on the individual circuits to vary their tuning, it is possible by displacement of turns or groups of turns to pre-arrange that the individual preliminary magnetisation coil and the individual oscillatory circuit coil match one another as accurately as possible; alternatively, however, the cores per se themselves, which are rather soft can also easily be corrected for balancing purposes by cutting off particles or by deformation. Finally, it may be preferable to make the mass cores conical, whereby adjustment may be effected by adjusting the extent to which the mass cores enter each particular coil. Likewise, the small blocking condensers which serve for completing the oscillatory circuits may either themselves be rendered slightly variable by compression screws in order that adjustment may be effected, or else small variable condensers, similar to the well-known trimming condensers pro-

vided on ganged rotary condensers may be connected in parallel with the blocking condensers, to permit exact balancing. The variation of the receiving ranges, in this case, may be effected either in the normal manner by the connection and disconnection of groups of turns or else by the parallel-connection of larger or smaller blocking condensers.

The construction of tuning variometers is also very much easier to carry out by means of ferromagnetic iron cores, since the coupling can be varied by changing the position of the coils to a much greater extent if the flux is concentrated by ferromagnetic cores. The various attempts to construct receivers which allow of receiving the whole wave band, by simultaneous variation of capacity and inductance, on a single revolution of the interconnected variable tuning elements, therefore, become much more promising here without having to resort to such dimensions of the condensers that strong damping and thus unfavourable reception results.

The method of automatic volume control already mentioned above can, of course, also be combined with the described method of tuning by varying the preliminary magnetisation, in which case very simple apparatus are then obtained in which both tuning and volume control are obtained merely by varying the preliminary magnetisation in different windings. Since very few mechanically moved tuning means are required, the invention provides ideal apparatus, particularly for remote control, since manual volume control can also be effected by variation of the preliminary magnetisation. An apparatus is thus obtained wherein single-knob tuning of almost any desired number of oscillatory circuit together with both manual and automatic volume control is merely by varying the current intensity of preliminary magnetisation currents, an operation which can be effected from any number of points located at any distance from the receiving apparatus. Such apparatus are particularly suitable in combination with amplifiers constructed in accordance with co-pending application No. 415,079. The use of saturating tubes in the anode circuits as described in the above application considerably simplifies the construction of the means parts of the apparatus and the decoupling arrangements, owing to the intense filtering action of these tubes against mains alternating current and also due to the mutual decoupling action of the individual stages, so that an extremely simple apparatus is obtained. In order, to prevent the emission from the cathodes, when using photo-cathodes in the saturating tubes from being dependent upon the general intensity of illumination at the receiving station, artificial illumination is of course used for this purpose. This can be obtained, for instance, in an apparatus which is provided with indirectly heated tubes having high voltage cathodes for direct connection to direct and alternating current, by using for the production of the artificial illumination that part of the mains voltage, which must be taken up in breaking down the mains voltage to the voltage required for the cathode operation. However, since mains fluctuations are manifested in a disturbing manner in this case by fluctuating disturbance of the photo-cathode current, it is desirable to use light radiators which are very inert thermally, such as for instance, lamps, constructed in the manner of the well-known Nernst lamp. This form of illumination is desirable in all cases where

normal lamps cause excessive disturbances in operation with photo-cells, such as, for instance, in the reproduction of sound films etc.

By the combination of the above described tuning and volume control by variation of the preliminary magnetisation with the suggestion last mentioned, which are described in the present applicant's prior application above referred to apparatus are obtained which are of extraordinary simplicity and reliability. However, by employing the method of tuning based on a variable preliminary magnetisation, it may be difficult in some circumstances to cover a sufficiently large range of reception without the connection and disconnection of condensers or coil parts. In this case, the range to be received may be subdivided into a relatively large number of wave ranges in the manner described in copending application No. 409,737, in which case, as has been described in detail in the prior application, this sub-division has the further advantage that the balancing of several simultaneously tuned oscillatory circuits is substantially simplified, so that a particularly simple form of single-knob manipulation is thus obtained.

The variation of the preliminary magnetisation can also be employed even to obtain the adaptation of the mains transformer to incidentally occurring mains fluctuations or else to construct a mains transformer which can be employed without change of connections on different mains voltages. To this end the effective inductance of the core is varied by means of rectifier current from a secondary winding for instance, the current from the secondary winding supplying the anode current which must, in any case be rectified in such a manner that as the mains voltage increases, the secondary voltages decrease, at least in those windings where excess voltages are dangerous, that is particularly in the heating windings. A fluctuation of the anode voltage is generally not so detrimental, owing to the fact that the grid bias is usually produced at the present day by the voltage drop in a resistance, whereby the grid bias automatically adapts itself to the changed anode voltage and automatic control of the volume can be effected in any case. Hence, a small auxiliary transformer which merely supplies the heating current for the tubes, can be regulated by means of a main transformer, which supplies the anode voltage and the like. The tuning and regulation become very simple, of course, when superheterodyne receivers are employed, particularly of the kind according to prior Patent No. 301,498 and the addition thereto No. 313,414, since in this case only the tuning of single circuits is to be varied, which of course renders any type of balancing superfluous. Automatic noise suppression in combination with automatic fading compensation can also be obtained in simple circuits even with a pure form of magnetisation curve, since the curve exhibits a mean straight part, which would then serve for maintaining the sound volume within certain limits while the first flattening which occurs at the beginning of the curve may be used for noise suppression while the second flattening which occurs at saturation may be employed for the compensation of fading. In the same way, of course, the constructional examples described here primarily for fading compensation can be used for the correction of amplitude in sound film and sound disc recording and such cases.

The method of inductive tuning herein de-

scribed may be used also in the case of capacitative tuning, wherein a tuning capacity is used which is varied by a bias. To this end use may be made as tuning condenser of an arrangement such as an electrostatic loudspeaker, wherein by varying the bias the capacity is varied. The above description as applied to inductive influencing may then be read as applying to capacitative influencing.

A number of further possibilities which arise when using mass cores of the nature of Ferrocarr material may be mentioned. In the first place, it is possible to obtain mechanical attraction of such cores as with normal alternating current magnets. This fact enables for instance, high-frequency relays to be constructed for use in transmitting and receiving circuit, particularly in receiving circuits, wherein a mass core attracts an armature of an identical ferromagnetic high-frequency mass. However, telephone receivers, loud-speakers, sound recording instruments and the like can then also be directly constructed, which enable direct conversion of high frequency oscillations into mechanical oscillations and vice-versa. Similarly voltmeters and ammeters adapted to be directly operated with high frequency, galvanometers, power meters, etc., may be constructed in which, however, the normal types of iron are replaced with such mass material. In this case, amplification of the action may be effected by introducing back-couplings, by means of discharge tubes or other amplifying means. Therefore, for instance, in a telephone, the mass core of which is directly energised by high-frequency currents, amplification can be obtained by the use of high-frequency back-coupling. Of course, low-frequency back-coupling would also be possible per se. Nevertheless, the high-frequency back-coupling in this case has the advantage that no appreciable distortion is introduced thereby. Since, however, as has been shown above, tuning may be effected by varying the preliminary magnetisation or the coil-spacings with respect to one another or to the iron core or the like, it is possible in this manner to combine both the tuning circuit and the reproducing instrument and possibly also a volume control all into one constructional element.

In the devices mentioned for the conversion of mechanical into electrical energy, it is possible, for instance, with sensing members, either to vary the coupling at more or less constant frequency by variation of the preliminary magnetisation or the like, or else to vary the frequency whereby the transfer of energy between two circuits is then varied due to the de-tuning between two circuits. The above suggestion for the construction of high-frequency instruments operating directly in high frequency by the method usual for low-frequency is also of particular application in directional reception, since in such apparatus the goniometers can then be constructed in like manner to soft-iron instruments. Thus, by more or less intense preliminary magnetisation, which can possibly be obtained by permanent magnetic fields, asymmetry of the magnetic fields may be obtained on change of direction of the high-frequency current, so that instruments can even be produced on the system of moving-coil direct current instruments.

By virtue of the asymmetry of the magnetic fields in the reversal of polarity of the current in a sufficiently pre-magnetised iron core, demodulations and modulations can also be effected with such mass cores. Therefore, such a mass

core with corresponding windings and pre-magnetising coil etc. may also act as a demodulator in receiving circuits and thus fulfill the function of detector tubes. Since, for instance, in heterodyne receivers, two tubes acting as detectors are required then in such a case by means of the use of suitable coil or transformers, two tubes may be replaced by a mass core. This constitutes a considerable simplification. In order to replace the first tube, such an arrangement would have to act both as a modulator and demodulator, but in the second case, for the conversion of the intermediate frequency into the low frequency merely as a demodulator. Another tube is definitely required for the local generation of oscillations in heterodyne reception. Since, however, for the generation of oscillations work can be done on the straight part of the characteristic of a tube, then a low-frequency tube, preferably the output tube in reflex connection may be used for the generation of oscillation since in this case, owing to the great flexibility of control complications should least be expected. If the reflex system is also used elsewhere in such receivers, heterodyne receivers may be constructed with very few members. Since the tuning in such receivers can also be obtained by varying the effective inductance in accordance with the aspects given above, a receiver may be designed of a simplicity hitherto hardly known.

For the remote operation of receivers, it is important that the change-over of the individual wave bands should be effected with the same current as effects the variation in tuning. This can be effected in a simple manner by interrupting and re-inserting the current employed for varying the inductance or for volume control, the interruption and re-insertion electro-magnetically setting into motion in the receiver an escapement wheel which sets a wave-band changing shaft into rotation. Since, as above described the actual tuning circuit may be completely decoupled from the circuit effecting the preliminary magnetisation it is immaterial in which direction the preliminary magnetisation current flows. By means of a polarised driving mechanism for the escapement wheel the latter may be rotated, for instance, clockwise, on the passage of a current in one direction, while on reversal of the direction of the current the escapement wheel is moved in the anti-clockwise direction as the circuit is broken and remade. Therefore, by means of a suitable commutator switch arrangement in the remote controlling apparatus in cooperation with the escapement wheel mechanism described, it is possible to effect rotation of the wave band change-over switch in the actual receiving apparatus in either direction from the remote controlling apparatus.

Since, the direct current component of the anode current in the demodulation devices owing to the selectivity of the receiving circuits, varies with variation of the tuning when a given transmitter is being received, this current variation may also be employed for the subsequent automatic correction of the tuning, since the direct current component of the anode current can then be used to vary the preliminary magnetisation to effect correction of the tuning circuits. Hence, it is possible in this manner to construct automatic self-tuning apparatus, or apparatus, which one tuning is effected, automatically adapt themselves to variations of frequency of the oscillations received.

Since the inductances provided with mass cores

herein described may be used to replace modulation tubes, they can also be used in arrangements made in accordance with a prior invention of the present applicant to replace discharge tubes by inductance coils or transformers. In the arrangement for multiplex telegraph according to the prior invention use is made of two parallel tubes, the grids of which are energized in opposite phase by a local oscillation. These tubes can be replaced by corresponding transformers of the type herein described. In the prior arrangement relays are shown connected in the anode circuit of the tube. These can now be dispensed with, since the mass cores of the said transformers may themselves be designed as relays and so permit conversion of the oscillatory energy into mechanical energy directly. The arrangement according to the prior invention may also be used for the analysis of frequency mixtures, by applying a control frequency variable in accordance with a well-known law to the control grids, whereupon a pointer or the like connected to the relay armature employed therein gives a strong deflection when the control frequency conforms with the frequency of a component of the current mixture supplies to the anode circuit, by application of the principle herein discussed, the tubes may be replaced by mass cores provided with a suitable winding, and an instrument can therefore be constructed which acts directly as frequency analyser without the aid of discharge tubes, if a known variable auxiliary frequency is supplied. The different constructional examples indicated in the above application can be combined among themselves, so that an extremely large number of possibilities of use is obtained.

A further application of the invention relates to heterodyne receivers and more particularly those which are constructed in accordance with prior Patents No. 301,498 and 313,414, wherein an aperiodic input or, at least, an input which acts aperiodically over a part of the receiving range is employed as the mixing tube, this aspect of the invention, however, being in no way limited to these special types of receivers. In such receivers, one of the most important drawbacks is the strong crackling often complained of, which arises from the mixing tube and is then amplified to large amplitudes by the subsequent, usually powerful, intermediate frequency amplification. This amplification following the frequency changer was previously desired when difficulties still existed in the amplification of short waves. At the present day, these difficulties are obliterated to a great extent, and it is therefore now proposed to arrange the entire amplification before the mixing tube, whereby the noises arising in the mixing tube can be rendered small in relation to the receiving oscillations which reach this tube already fully amplified: In this case, of course, it is immaterial whether the amplification is effected by discharge tubes or by a back-coupling effect.

In addition to the suppression of the crackling tendency, however, other, considerable, advantages are also obtained by means of this arrangement. For instance, a finer anode rectification can easily be used, since the amplitude of the receiving oscillations applied to the control grid of the mixing tube after amplification can in any case be made so large that work is no longer done on the changing curvature at the lower bend of the characteristic, but the half-waves to be rectified extend into the straight part of the

characteristic, so that a linear instead of an exponential action results, which is desirable for many cases. However, it is also advantageous in this receiver to employ the recent mixing arrangements employing pentagrid or hexode tubes such as described in copending application No. 409,756 with multiplicative instead of the additive or subtractive intermediate frequency formation. Since, in accordance with the present proposal it is important to avoid any considerable amplification after the mixing tube, it is also desirable to avoid subsequent powerful low-frequency amplification. It may therefore be preferable to apply the output from the rectifier directly to the loud-speaker or even, as described above to dispense with all low frequency parts and allow the high frequency to act directly on an electrostatic or electromagnetic high frequency loud-speaker (provided, for instance, with Ferrocart-like mass cores). Between the rectifier or high-frequency loud-speaker and the mixing tube in place of the usual intermediate frequency amplifier, merely an intermediate frequency filter chiefly comprising several members should be arranged which may be constructed in a manner well-known per se as a chain conductor or may comprise mechanical resonators such as quartz crystals.

Particularly if, aperiodic or semi-aperiodic input circuits are employed as suggested above, it is desirable to use for the amplification effected before the mixing tube, tubes or combinations thereof according to copending application No. 415,079 since these tube combinations provide very high amplifications in combination with relatively low internal tube resistances. This is an important point in aperiodic or semi-aperiodic amplifiers owing to the relatively low dynamic resistances which may be given to such circuits for the adaptation thereof to the tube resistances. As has been mentioned in the last-mentioned application, in the case of high-frequency amplification, such series-connected tubes must be arranged so that the capacity of the connecting leads of the successive systems, is as low as possible, and to this end tubes with indirectly heated cathodes, which eliminate the capacity of the heating current source, and multiple tubes which keep the capacity of the connections between the individual systems low, are employed. If several systems are used in this manner, the construction of a multiple tube may become rather complicated and thereby give rise to a large quantity of waste. In this case therefore, instead of combining the whole in a single multiple tube it is desirable to provide each system or small group of systems in a separate tube, but to construct individual tubes so that they can be connected one to another with supply leads led out directly instead of through a base, so that in practice the advantages of the short direct connections provided in multiple-tubes are obtained but in manufacture the advantages of the production of single or two-system tubes exist, the tubes being combined at will into multiple-system units.

Since, when using a comparatively large number of series-connected systems, very high voltage amplification is obtained and also since an anode current source, i. e. say, the mains-transformer etc. is designed for operation on high voltage and relatively small current, this type of apparatus is particularly suitable for combination with electrostatic loud-speakers.

In these methods of reception with aperiodic

or semi-aperiodic input circuits, there is the advantage already emphasized in the prior patents referred to that single-knob manipulation is thereby obtainable in a very simple manner. It is very desirable for the constitution of these circuits to use coils with ferromagnetic cores at least for the construction of multi-element filters in order to avoid stray fields and in consequence undesirable couplings, and if this is done it is possible to go a step further and, by the use of an adjustable preliminary magnetisation to use these ferromagnetic cores in the manner above described in place of rotary condensers, for tuning in to various waves to be received. The difficulties with this method of tuning, i. e. by preliminary magnetisation, in the case of a plurality of tuned circuits arise from the necessity of keeping the individual circuits in resonance over the entire receiving range, and these difficulties are avoided here, since when using aperiodic input circuits, only one continuously variable tuning means is provided and when using semi-aperiodic input circuits, the necessity of observing absolute accuracy of the tuning between the individual circuits is dispensed with.

The necessity for accuracy of tuning can be still further reduced in the latter case by dividing the total wave range into a large number of small ranges according to copending application No. 409,737. In particular, if several simultaneously tunable circuits with variable permeability tuning are provided, this is of advantage. With this type of tuning, which is particularly suitable for the remote control tuning of apparatus, the design of the tuning scales at the receiving apparatus or at the individual remote-operating place can then also be very conveniently designed. Since in this method of tuning as already described in copending application No. 409,737 the delicate mechanical adjustment is replaced by a form of electrical vernier, a very simple mechanical equipment is sufficient at the individual remote-operating places.

The tuning scales are preferably constructed as "panel-scales." At the front of the receiving or remote control apparatus there is provided a plate of, for instance, milk glass of suitable dimensions (say 10 by 20 cms) which is divided into horizontal and vertical strips. If the plate is placed crosswise, strips are obtained which owing to their elongated form, are of suitable shapes for the inscription of station names. Each column then corresponds to one of the relatively small wave bands and the individual strips constituting a column correspond to the individual stations to be received within this band. The scale may be illuminated from the rear and there may be arranged on the apparatus as a wave switch, a plane sliding switch, the switching arm of which is movable behind the scale in such a manner that when connection is made for the reception of the shortest wave band, it is situated just behind the horizontal row which corresponds to the shortest band and, when the wave band connection is changed it comes into the corresponding position behind the wave band now switched in. If a small lamp is fixed to the switching arm, the range switched in at any time is always illuminated. By means of the knob effecting the tuning within a selected range, the lamp may then be moved to and fro in a vertical direction behind the scale plate on a runner or the like, so that the strip bearing the name of the station being received is then illuminated. Alternatively a long horizontal pointer may be pro-

vided which moves in front of or behind the scale and which indicates the station in the column illuminated at the time, to which the apparatus is tuned. Such a panel scale, as will be hereinafter described can also be suitably constructed for use at a remote-controlling post.

Remote tone control by the variable induction of presaturated low-frequency chokes or transformers may also be employed.

The remote tuning mechanisms herein described are, of course not limited to the provision of a panel scale as herein described any more than the panel scale is limited to this manner of application, since it is suitable generally on sub-division into a larger number of individual ranges, particularly in the arrangements according to the prior patent application No. 405,737 above mentioned. The methods of execution of the limited tuning or operation herein described are not only applicable to the special methods of reception described here and in the last mentioned application although they are particularly suitable therefor.

The method according to the invention, can be used with very great advantage for yet another element in the tuning of a set, namely, not for operation of a continuously variable tuning element i. e. for replacement of the rotary condensers, but may also be used to replace the step-by-step tuning of an inductance by wave change switches. In this case, special advantages are obtained. As is well-known, it is a great disadvantage of all apparatus working with a wave change that change-over switch contacts must be provided in the high-frequency circuits, since, firstly, the connection of the lines from and to the contacts causes difficulties, since all capacitative effects in such circuits are to be avoided to the greatest possible extent. In addition, the lines to the change-over switches and the change-over switch contacts give rise additional dampings, apart from the undesired capacitative couplings, and finally also the mechanical structure of these multiple switches is complicated and expensive.

All this can be avoided by the step-by-step switching or pre-magnetising currents, which offers great advantages, in particular, when a large number of changes of connections is to be effected, such as, for instance, in an apparatus constructed according to copending application No. 409,737.

All tunings effected by saturation such as hereinafore mentioned and more particularly, those just discussed permit in other respects the use of much higher permeabilities than, for instance, are obtained with the Ferrocarr-like materials, wherein during operation, the inductance value remains unchanged. This is due to the fact that in the case of the materials the permeability of which remains unchanged, the permeabilities must be so chosen that even at the smallest wave length arising, the damping is not too great, whereas in carrying out the present invention, the permeability is so chosen that in the condition of the maximum preliminary magnetisation, the permeability is a minimum, the damping is kept within the desired normal limits for the smallest wave lengths while in the case of higher wave lengths at which a higher permeability does not bring any objectionable increase in damping, this increased permeability can then also be effectively utilised. This applies particularly to the step-by-step inductance switching here described, since here the maximum permeability comes into action at wave lengths which behave particularly favour-

ably as regards the damping with ferromagnetic cores.

The step-by-step tuning by varying the current intensity or voltage of a pre-magnetising current in steps may even be used in the case, owing to its special advantages, in arrangements which are otherwise normally tuned, that is tuned by rotary condensers or variometers or in combination with the methods of tuning hereinbefore described, so that the step-by-step and also continuous tuning can then be effected by the same or even different preliminary magnetisation coils on the same or on different cores.

It is also very suitable, particularly for remote tuning, however, to combine the continuous tuning (described above) with a step-by-step tuning by variable preliminary magnetisation by means of electric biasing of condensers, for instance, Selgnette salt condensers, for the purpose of remote operation of receiving installations having several tuning circuits by a single-knob.

In particular, for such cases in which a high degree of curvature of the magnetisation curve is desired in addition to a high degree of variation of the permeability at the working point, that is, especially in those cases where a modulation phenomenon is desired, there is a certain drawback with cores such as Ferrocart cores, having a fine subdivision in the distribution of direction of the lines of force, the magnetisation curve presents only slight curvatures. According to a feature of the present invention therefore, a magnetic core is provided which is hereinafter described, and which has proved to be particularly suitable in such cases, and also in all the other cases which are mentioned in the main application.

Since very sharp bends can be obtained in the magnetisation curve even with relatively small magnetomotive forces, if the ferromagnetic material is suitably chosen, this material is also particularly suitable for the construction of magnetic amplifiers which operate on the principles well-known per se, such amplifiers could only be constructed for relatively low frequencies in the past, owing to the high iron losses.

In order that the various aspects of the invention may be more clearly understood, a number of embodiments thereof will now be described with reference to the accompanying drawings in which,

Fig. 1 shows a simple volume control arrangement.

Fig. 2 shows a modified form of volume control arrangement similar to that shown in Fig. 1.

Fig. 3 shows an arrangement for obtaining automatic volume control.

Fig. 4 is still another form of volume control.

Fig. 8 shows diagrammatically the circuit arrangement of a superheterodyne radio receiver embodying a feature of the invention.

Fig. 9 shows a tuning indicator arrangement and remote controlling apparatus for use in conjunction with the invention.

Fig. 10 is a remote control circuit which may be employed, according to the invention, in conjunction with the other remote control arrangements described.

Fig. 7 shows an arrangement for effecting step-by-step alteration of an inductance.

Fig. 6 is an elevation and

Fig. 5 a section of a form of core suitable for use in carrying into effect the various features of the invention.

Referring first to Fig. 1, which shows a vol-

ume control arrangement a tube 1 is shown adapted to operate, for instance, as an anode current rectifier, so that an increased amplitude at the grid, produces an increase in the anode direct current component. An oscillatory circuit 2 is connected to the grid of the tube. The anode circuit of the tube is provided with a back-coupling coil 3 and variable leak condenser 4. According to the invention, the back-coupling coil is coupled to the oscillatory circuit through a ferromagnetic core 5, the inductance of the ferromagnetic core being of such a value that favourable operation of the back-coupling is just obtained with the preliminary direct current magnetisation due to the anode current which passes at the desired volume. The adjustment of such a close back-coupling is effected by means of a variable condenser 4. If the capacity of the condenser 4 is made very large the high frequency component is mainly conducted to the cathode without traversing the coil 3 and a slight back-coupling action takes place, while on the other hand, if the capacity is reduced, the back-coupling effect increases. If strong signals are now received, which cause a substantial increase in the anode current, the action of the back-coupling decreases accordingly since the increased preliminary magnetisation reduces the mutual inductance of the coil 2 and 3. The reverse action may also take place. In this case, therefore, a very simple type of volume control is obtained. Any de-tuning of the circuit 2 which occurs may be compensated in any suitable manner if it is undesirable, although as stated above, additional volume control may be obtained thereby. Any desired adjustment of the time constant of the regulating operation can be obtained by condenser and resistances or the like, suitably incorporated in the anode circuit.

In Fig. 2 a modification of regulating device for the regulation of back-coupling is illustrated, which has an even more intense action to some extent. In this case, a three-limb core of ferromagnetic material is provided, which carries three different coils or groups of coils. The coils 1, 2 are connected in a tunable oscillatory circuit, which may be connected to a tube acting as rectifier. These two coils are wound in such a manner that the field they generate in the coil core are in series. The field produced by them, therefore, does not substantially penetrate the centre limb of the transformer. On the centre limb of the core there is arranged a coil which is traversed by the high-frequency components of the anode current of any succeeding high-frequency amplifier or the detector tube to which the oscillatory circuit 1, 2 may be connected. As long as the inductance in the two symmetrical portions of the three-limb transformer I and II is uniform, no back-coupling effect will occur at all, since the oscillatory circuit is decoupled from the back-coupling coil in this condition. The core of ferromagnetic material or the oscillatory circuit coil may be so designed that complete mutual decoupling occurs when a certain normal current flows through the turns 3, 4 connected in opposition to one another, which are traversed by the direct current component of the de-modulation tube. If the volume falls below this desired degree, then the consequent reduction in the preliminary magnetisation by the two coils 3, 4 unbalances the symmetry in the two magnetic circuits I, II so that coupling takes place between the oscillatory circuit 1, 2 and the back-coupling coil, such coupling being intended to set in such

a manner that the back-coupling coil has an amplifying action. If, however, the field strength of the incoming oscillations becomes very great, so that the anode current in the rectifier tube considerably increases, the symmetry of the arrangement is displaced in the opposite direction and the back-coupling coil now acts additional damping, that is reduces the volume. For this effect to be produced, of course, it is necessary that initially, that is, without the action of the coils 3, 4 a symmetry exists between the circuits 1, 2, so that a close back-coupling is then already present, thus a symmetry being gradually removed, as the direct current in the coils 3, 4 increases, extended increase in the current in the coils 3, 4 leading to asymmetry in the opposite direction. The arrangement just described owing to mutual compensation of the action in the coils 1, 2, provides automatic volume control without any variation of the tuning.

A third example of an arrangement providing automatic volume control is shown in Fig. 3. In this case, the coupling per se is varied in place of the back-coupling. I is, in this case, the input circuit of a coupling arrangement, while II is the output circuit. The arrangement may be a transformer coupling two high-frequency amplifier stages or the like. As can be seen, the transformer has 3 groups of windings, namely, a coil 1 which is connected to the input circuit, a centre-tapped coil 2 from which the output circuit is so derived that, if the coil is tapped symmetrically no oscillatory energy can reach the input circuit and, furthermore, a second two part winding 3, 4 through which the direct current component of the demodulation tube flows. In this case also the tapping of the coil 2 may again be made asymmetrically at the outset or the mass core may be asymmetrically designed or both, so that normally, without direct current in the windings 3, 4 or with only a small direct current component, a considerable asymmetry is present, whereby an essential part of the input at I may be derived at II, while as the preliminary magnetisation by the coils 3, 4, increases the asymmetry is gradually removed and finally the bridge or the differential system, on very strong preliminary magnetisation, gradually approaches balance, so that the current component which is transferred from I to II continuously diminishes.

If the coils 1 and 2 are parts of tuned coupling transformers between individual amplifier stages, where the de-tuning may be undesirable, this de-tuning may be counterbalanced, as has already been described in connection with the example shown in Fig. 2 by the counter-connection of similar elements so that no undesired de-tuning of the circuit then occurs.

The great advantage of such volume control arrangement resides in the fact that although no special tubes and no special grids in the tubes are employed, a variation of the volume can be obtained, which, in multi-stage apparatus, such as multi-stage amplifier, where a regulating stage may be arranged before each amplifying tube, multiplies the action in the individual tubes, and so allows of obtaining regulation within very wide limits. In the arrangement described in Fig. 3 wherein the preliminary magnetisation only acts to vary the energy transmitted from circuit I to circuit II it is also possible since there are no tuning problems in this case to effect the regulation in the low-frequency part or else in the high-frequency and low frequency part together. If the regulation is effected in the low-frequency

part, it is possible to dispense with the use of special types of iron.

A further development of the invention idea is shown in Fig. 4. In this case, I is again the input circuit of a coupling arrangement which is variable for the purpose of volume control and II the output circuit. 1 and 2 are normal fixed inductance coils, while 3 and 4 represent two inductances variable by preliminary magnetisation. The bridge arrangement comprising the four resistances 1, 2, 3, 4 is initially balanced, that is, when only the preliminary direct current magnetisation by the battery 5 is effective in the coils 3, 4 and there is no preliminary magnetisation by the centre tapped coils 6 and 7, then the bridge is in equilibrium. If preliminary magnetisation arises in the coils 6 and 7 the equilibrium of the bridge is disturbed, since the inductance of the coil on the core 3 is increased and the inductance in the coil 4 is decreased to equal extents. A considerable flow of current will then take place in the arrangement from the input part I to the output part II. The preliminary magnetisation of the cores 3 and 4 is effected by the following manner. The two tubes 8 and 9 again represent rectifiers, which are energised by an oscillatory circuit 10, which may be assumed to be connected to the output of a high frequency amplifier. The circuits I and II may be the coupling between two or more stages within this high-frequency amplifier. The tubes 8 and 9 then, act as rectifiers and in the present figures, for the sake of clearness, the part of the lines which leads to the low-frequency amplifier is omitted and only that part of the lines of the anode circuit of the tubes 8 and 9 is shown, which carries direct current. In this case, means, not shown, may also be provided which effect the filtering of the alternating current component.

The two tubes 8 and 9 are intended to work with somewhat different biases, e. g. tube 8 with normal negative bias, so that it acts as a normal anode rectifier tube, and the tube 9 with so great a negative bias that the tube begins to function only at considerable amplitudes. When signals of very low intensity are received, so that it is to be feared that the material part of the audion only comprises strongly reproduced disturbances, then owing to the small anode direct current of the tube 8 and the tube 9 in the coils 6 and 7, no appreciable direct current at all will flow, so that, the original equilibrium of the bridge is not disturbed and practically no output is transmitted from I to II, that is, not even the intense disturbing noises, which are otherwise always present as a disturbing factor in a sensitive receiver on adjustment to maximum volume. If signals of a moderate sound intensity occur, the anode direct current of the tube 8 increases and, hence an increasing magnetisation is produced in a half of each of the coils 6 and 7, which as has already been mentioned, act in the opposite sense on the cores 3 and 4 so that in one core the preliminary magnetisation proceeding from the battery 5 is increased and in the other, it is decreased. Thus the equilibrium of the bridge is disturbed and a good transmission of the energy from the input circuit from I and II is effected. If the signal intensity considerably increases the tube 9 will also come into action, so that if the signal amplitude becomes greater than the negative bias of the tube 9, this tube then also passes an anode direct current. Hence, anode current is now supplied to coils 6 and 7 from both tubes 8 and 9. Since the two halves of the coils 6 and

7 act in opposition to one another, however, simultaneous operation of the tubes 8 and 9 acts to remove the preliminary magnetisation in the coils 8 and 7 and the bridge is again balanced so that the amount of energy which is supplied from the input circuit I to the output circuit II is kept constant.

Here again therefore an arrangement is provided, wherein automatic volume control and automatic noise suppression is provided. The coil combination shown here can also be arranged in several stages of a multi-stage high-frequency amplifier or even a low frequency amplifier, so that regulation within very wide limits can take place. In this case, it is note worthy that the input circuit I can be tuned, since the total inductance of this circuit (if no considerable load is applied to circuit II, that is, for instance, only the input of a tube amplifier) does not vary. The total inductance consists of two part-inductances connected in parallel, i. e. the part-inductance of the coil 1 in series connection with the iron-core coil 3, and, the part inductance of the coil 2 in series with the iron core inductance 4. Since, however, in the regulating operation, the inductances of the coils 3 and 4 are varied in opposite sense, then provided this variation takes place to some extent in a linear manner, as may be contained within wide limits of time by a suitable coil and core arrangement for instance, conical iron cores or the like may be used, the total inductance will not vary during the regulating operation, so that these coils may be parts of a tuning circuit.

Referring now to Fig. 8 this shows a super-heterodyne radio receiver constructed according to a feature of the invention. As is readily apparent from the drawing, the apparatus comprises two stages of series connected amplifier tubes, each comprising two tubes 21, 22 and 23, 24 connected in the manner according to co-pending patent application No. 415,079 the two stages are coupled through a band-pass tuned circuit 25. The output of the two stages of high-frequency amplification is applied through a further band-pass tuned circuit 16 to the mixer tube 27 shown as a hexode or four-grid tube. The intermediate frequency from the mixer tube 27 is applied by way of transformer 28 and filter 29 to a second detector 30, in the anode circuit of which the loud speaker L is connected.

The high-frequency signals picked up by the aerial 31 are amplified in the two stages of high frequency amplification to such an extent that, after frequency changing by the tube 27 and detection by the tube 30, a sufficient output is derived to drive the loud speaker L without low frequency amplification.

Preferably, the tuning arrangements are constructed according to co-pending patent application No. 409,737, whereby the condensers forming part of the coupling circuits 25 and 26 and the tuning condenser for the local oscillation generating circuit 32 may all be ganged together without difficulty and may even be condensers of the solid dielectric type.

In Fig. 9 a further development of the invention is shown. In this figure, T is an instrument which is traversed by the premagnetising current and indicates its strength. However, since this current, is proportional to the receiving frequency, the instrument can be directly calibrated in wave lengths. By means of a second lever pivoted at D, a parallel ruler mechanism is formed whereby the long pointer Z may

be maintained horizontal and guided up and down in front of or behind a panel scale divided, for example into five parts. Connected in series with the instrument T is a regulating resistance R, which enables the intensity of the pre-magnetising current and thus the tuning of the receiving apparatus to be effected. The resistance R is operated by a knob K which is mounted on a long spindle, which may be of square or other cross-section so that on rotation of the knob, the contact arm of the resistance regulator R is turned, but on movement of the knob in the direction of the spindle, the latter may slide freely.

The spindle A may therefore be used to displace the contact Y on the slide S by push or pull, so that it can be brought into engagement successively with the contacts 1-5. This contacting causes circuit interruptions or closures which cause the rotation of an escapement wheel in the receiving apparatus in the manner described above, said wheel causing the wave range change-over in the apparatus.

In this case, pressure on the knob K in the axial direction, moves the member M sliding frictionally on the spindle to effect a contact closure between the elements of the controlling apparatus and the lead U, while a pull on knob K, moves the member M in the reverse direction and makes contact between these elements and the lead V. The individual current impulses produced by contact of the contact Y with the individual contact points cause rotation of the escapement wheel effecting the wave range change in the apparatus in either one or the other direction, according to whether the impulses are transmitted to the receiving apparatus through the lead U or V, since the two lines U and V are connected either to two different lifting magnets or drive a polarised escapement wheel mechanism in either direction. The result is thus obtained that the position of the escapement wheel corresponds at any time to the position of the contact Y.

On the contact Y there is arranged a small lamp L_a which illuminates the area below which the contact for the time being in operation is located. The arrangement is preferably so devised that by means of vertical screens or the like, the adjacent fields are prevented from being noticeably illuminated also only the one area corresponding, to the wave band in use being illuminated, and the shadow of the long transverse pointer Z being devised on the milk glass or like plate only at that locality. The sixth contact point is shown in the present constructional example as an idle contact, so that by shifting the knob K into its end position, the apparatus can be switched off by interrupting the current interruption. It is preferable to ensure, by means of resilient stops or the like, that the contact cannot remain in an intermediate position between two contact points. Furthermore, a change-over to gramophone reproduction for instance, at the receiving apparatus, may be distinguished at the remote-control apparatus by reversal of the direction of the current or the like or by means of a special signalling lamp or by deflection of the instrument in the opposite direction, whereby the pointer is moved out of the range of the tuning scale and replaced by a template with an inscription which is depicted on the scale.

If remote control is to be effected from more than one point, the remote control line may be permanently connected up to the several points

(if a movable wire is not employed) and plug connections may be provided at these points into which a remote control apparatus of the above-described kind can be plugged. It is then only necessary for instance, in a dwelling-house with several living rooms—from which the operation is to be effected at will, to carry about the small and light remote-control apparatus to the room from which control desired. Alternatively a remote control apparatus may be permanently installed at each point which shows on permanently connected ammeters or voltmeters, which are calibrated in wave lengths in the above described manner, the wave length adjusted at the time from that or another place. In the latter case, however, it is preferable to provide a locking arrangement, whereby an adjustment cannot be made from one point if the apparatus is already being controlled from another point, since otherwise the escapement wheel mechanism in the apparatus might fall out of step. The connection and disconnection of the apparatus, however, can be effected in this case from any number of points by means of a circuit similar to the "series circuit" in lighting installations.

The individual operating points can be made more dependent of one another by the following arrangement. Means such as a holding magnet as used in the selectors for automatic telephones may be provided arranged on a device which may resemble the above-described remote control, which holding magnet, retains the knob K by means of a braking action of by a pawl and stops, in each position into which it is placed by means of the adjuster, in opposite to a restoring force formed e. g. by two springs. If the current is interrupted, the holding magnet or the holding magnets become currentless and the two springs i. e. a torsion spring and a lifting spring acting as restoring forces, rotate the resistance R into its zero position or initial position in which the circuit is broken, and move the contact Y onto the idle contact 6. Since, by the use of a "series circuit" as in illuminating installations the current interruption can take place at any operating point, this provides a possibility of effecting the operation at each point independently.

In this case, as described above, the reading instruments may remain connected at each point if desired, in order that the station to which the apparatus is adjusted may be observed at each point. If several wave bands are employed, a device must also be provided to indicate the particular wave band. This could be effected, for instance, by the arrangement of a separate signalling lamp under each scale section corresponding to a wave band, the lamps corresponding to each section being connected in series or in some other interconnection with the corresponding lamps at the other operating points. Loudspeakers may be permanently installed at the individual operating points or may be plugged in, in the same manner as the remote control apparatus. Alternatively a loudspeaker may be incorporated in the transportable control apparatus. When the apparatus is to be employed as a gramophone connection the changing of discs will necessitate providing the sound pick-up at the remote points, and talking-machine connections may therefore be provided at these remote controlling points, in which case care should be taken in the manner described above that the use of the apparatus for the time being as a talk-

ing machine is indicated at the other operating points.

The method of remote control above described, is not, of course, confined to its use for living rooms but may be used also when for any constructional reasons, the apparatus to be operated must be arranged at a place, which is inaccessible to the operator, thus for instance, on automobiles, aircraft, boats and the like.

In such cases also it may happen that the operation is to be effected either from the pilot's or driver's seat, or alternatively from the back seats, in which case at least two independent operating posts, should also be provided. This arrangement of independent operating posts may be effected in the manner already described or else by connecting all the lines concerned to each operating post as in a house telephone line-selector.

A further possible arrangement for independent operating posts is shown diagrammatically in Figure 10 by way of example. In this figure two such posts, are shown, in an installation such as for a motor-car wherein the apparatus is to be controlled from the back seats or from the driver's seat alternatively. The principle of the arrangement consists in using resistance branches, wherein by adjustment of regulating resistances, potentiometers or the like at different controlling posts, voltages or current intensities for the preliminary magnetisation may be derived. By this arrangement adjustment at one controlling post need not be varied or brought into the condition of rest before another controlling post can be employed, this result being achieved by the fact that the current consumers of the regulating resistances or the like which are provided at the various controlling posts are connected in a common circuit. Referring to Fig. 10 B is the current source required for obtaining the preliminary magnetisation, for instance, the battery of the motor car. The pre-magnetising winding in the apparatus, should be so arranged that the whole wave band for the time being connected up may be covered by variation of the voltage from zero up to half the available battery voltage. In other respects the windings may be constructed in all respects in accordance with the information set out above. The voltage applied to the pre-magnetising windings may be read off at either of the two controlling posts I and II from a voltmeter V1 or V2 calibrated in wave lengths or frequencies or station names, permanently connected in circuit. In the position shown, the sliders of the two regulator tappings R1 and R2 are approximately at the centres of their corresponding resistance strips. In this position they both have the same potential and zero voltage is therefore applied across the winding S connected between them. The longest wave is therefore tuned in. If one slider R is moved out of its position of rest, then independently of the position of the other slider, at least half the battery voltage may be applied to the winding S. The fact that, in this arrangement the direction of current may change is immaterial for the effect, since the winding S is completely decoupled. However, it is necessary to use voltmeters V, which give the same pointer deflection whichever the direction of the current unless opposite deflections are expressly desired for special purpose. The wave range change, however, can not be effected by means of change of direction of current and polarised escapement wheel mechanism, but must be effected in some other manner,

such as has been described above. The connection and disconnection may also be effected independently of one other at the control posts by "series-connection." Very often, a volume adjustment is required which may also be effected in the manner described above by means of saturating windings or in the same way as the tuning by electrostatic biasing of condensers dependent on voltage (for instance, Seignette salt dielectric condensers).

Turning now to Figure 7 this figure shows by way of example an embodiment of a further feature of the invention according to which the step-by-step variation of an inductance is effected by step-by-step variation of the preliminary magnetisation applied to a core with which said inductance is provided. In this figure, B is the current source, employed for preliminary magnetisation, which is shown here as a battery, but which in most cases will be replaced by a connection to the mains. R is a resistance variable in steps, which however, if continuous tuning by saturation is to be obtained in addition, may also have a continuously variable regulator connected in series therewith. Alternatively the resistance R may be continuously variable between the steps, and may be provided with stops, so that subdivision into several separate wave bands, even with a large tuning range of an apparatus, for instance from 200 to 2000 metres or more, is then dispensed with. K is the ferro-magnetic core which carries the relatively de-coupled pre-magnetising and oscillatory circuit windings. Further oscillatory circuits or back-coupling circuits of the apparatus, not shown here for the sake of simplicity are connected to the terminals X. Finally, Z is an additional resistance regulating arrangement the value of which may be adjusted to balance the initial values pre-magnetisation of the individual cores against one another; if the pre-magnetising windings of the cores are connected in parallel and not in series as shown here, the additional resistances Z should not be arranged in parallel but in series with the pre-magnetising turns.

Finally, Figs. 5 and 6 show diagrammatically a form of core, particularly suited to the various purposes of the present invention. Referring to these figures 11 is a coil body of thick paste-board or other insulating material, which serves not only as a former for the coil, but also to ensure that the winding on the core is sufficiently spaced from the conductive cores material, at least, where it is desired to provide a high-frequency winding whereby disturbing capacity couplings through the core material are to a great extent avoided. The coil former, which is shown homogeneous in the drawing may also be in the form of a framework structure, so that the H. F. turns touch the insulating material only at a small number of points, a sufficient air spacing for the reduction of capacitive noises being provided elsewhere. Since the finished core in the form herein described forms a self supporting whole, the insulating former can therefore be mechanically relieved to a great extent.

On the coil former there is wound a layer of thin ferromagnetic wire, for instance, iron wire or better an alloy such as permalloy, in such a manner that a small air-space is left between the individual turns, which considerably reduce capacitive coupling between the individual wire

turns. The thickness of the wire should not greatly exceed a diameter of 0.03 mm., thinner wires being still better.

After a layer of wire has been applied in the manner described, leaving sufficient spacings between the individual wires, this layer is preferably fixed and coated by a lacquer of good insulating qualities and of the lowest possible dielectric constant. Following this is an insulating layer, such for instance as paper, which is also fixed and then again, in the same manner as has just been described, another layer of wire or strip is applied. The wire or strip may possibly be produced electrolytically by deposition on a conductive base which is then dissolved away.

In the drawings 12 denotes the intermediate paper layer, and 13 the individual wires; 14 shows the arrangement of a layer of the H. F. coil winding. Since the core, as mentioned above, has sufficient mechanical stability after hardening of the lacquer, a direct current winding which is necessary for obtaining a preliminary magnetisation may be wound directly on the core. Hence, at the point where the direct current winding is arranged, the coil former is preferably removed since no reduction of the capacitive coupling is required, and a highly desirable gain in winding space is obtained.

Owing to the relatively low iron or the like content of the core, the permeability of course becomes considerably less than in massive cores or cores normally made of stratified material, but this is desirable for high frequency purposes owing to the consequent reduction in iron losses to tolerable limits. Moreover, sufficient saturation can be obtained in the matter with less current.

If the preliminary magnetisation is not produced by an applied winding but by arrangement of the core in the field of an additional permanent or electro-magnet, then of course by removing the insulating body at the particular points, provision should be made for good magnetic contact where the flux enters and leaves the core.

The cores described can be most simply produced economically in the form of closed circular rings since they can then be made on a simple coil winding machine with an arrangement well-known per se for the arrangement of intermediate paper layers between the turns, and it is therefore desirable to use two such cores for carrying out the various connection hereinbefore described. The direct current winding may then comprise two separate windings each arranged on a core, instead of the single winding illustrated in the figure. This last form of construction should even be the better one in regard to the attainment of a favourable filling factor.

The direct current winding and alternating current winding may generally be interchanged.

It has furthermore been mentioned above that the statement made for inductive operations when using cores of ferromagnetic material may also be applied to capacitive operations when using condensers dependent on voltage. Suitably constructed Seignette salt condensers are particularly suitable as such condensers.

This application is a continuation-in-part of applicant's co-pending application, Serial No. 749,088, filed October 19, 1934.

LADISLAS DE KRAMOLIN.