

PUBLISHED

JULY 13, 1943.

BY A. P. C.

K. B. W. KIEL

ADDING MACHINE

Filed Aug. 12, 1938

Serial No.

224,630

12 Sheets-Sheet 1

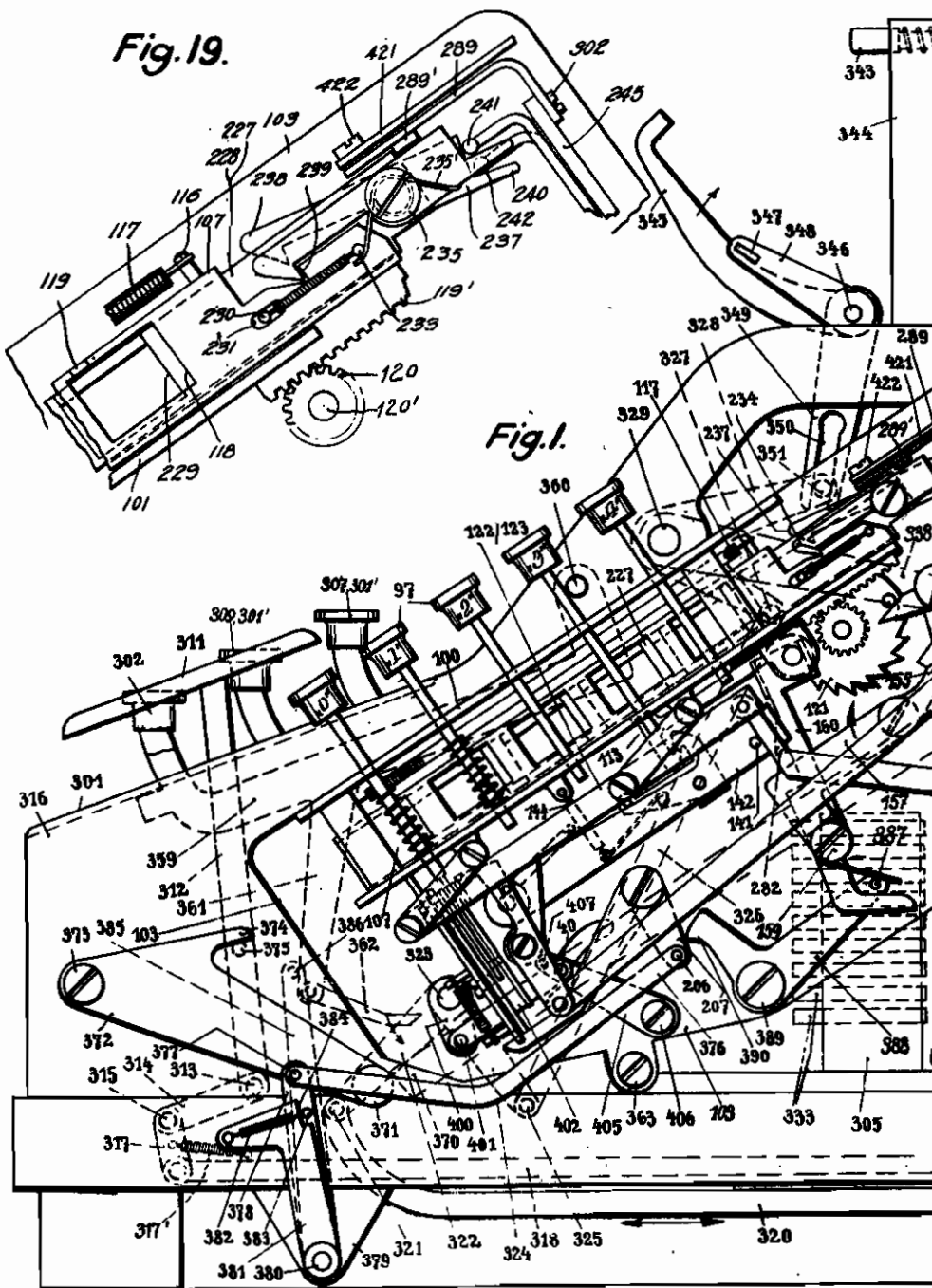

INVENTOR
 K. B. W. KIEL
 BY *[Signature]*
 ATTORNEY

PUBLISHED

JULY 13, 1943.

BY A. P. C.

K. B. W. KIEL

ADDING MACHINE

Filed Aug. 12, 1938

Serial No.

224,630

12 Sheets-Sheet 2

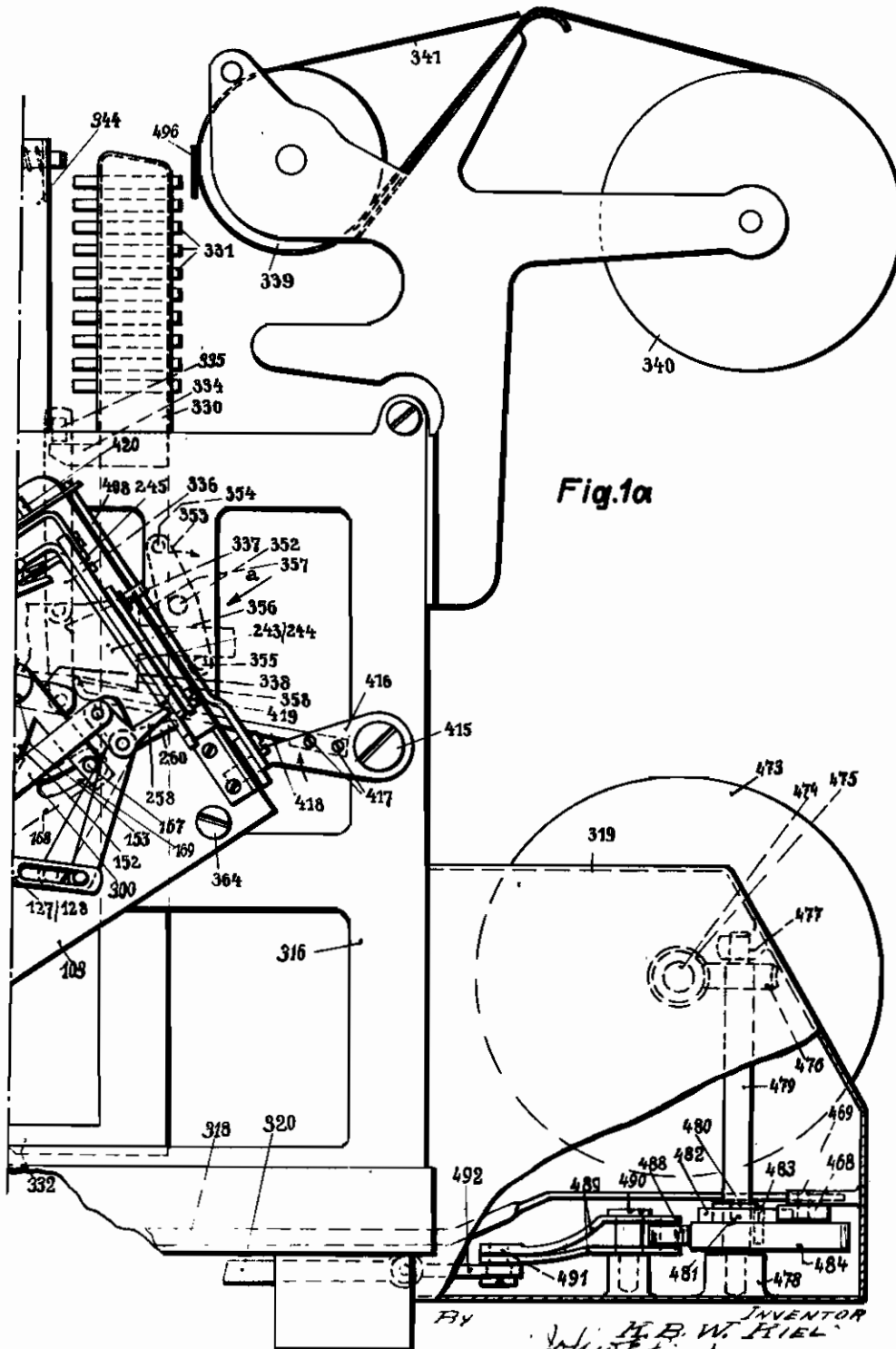

Fig. 1a

BY *John B. Ward* INVENTOR
H. E. W. Kiel ATTORNEY

PUBLISHED
JULY 13, 1943.
BY A. P. C.

K. B. W. KIEL
ADDING MACHINE
Filed Aug. 12, 1938

Serial No.
224,630
12 Sheets-Sheet 3

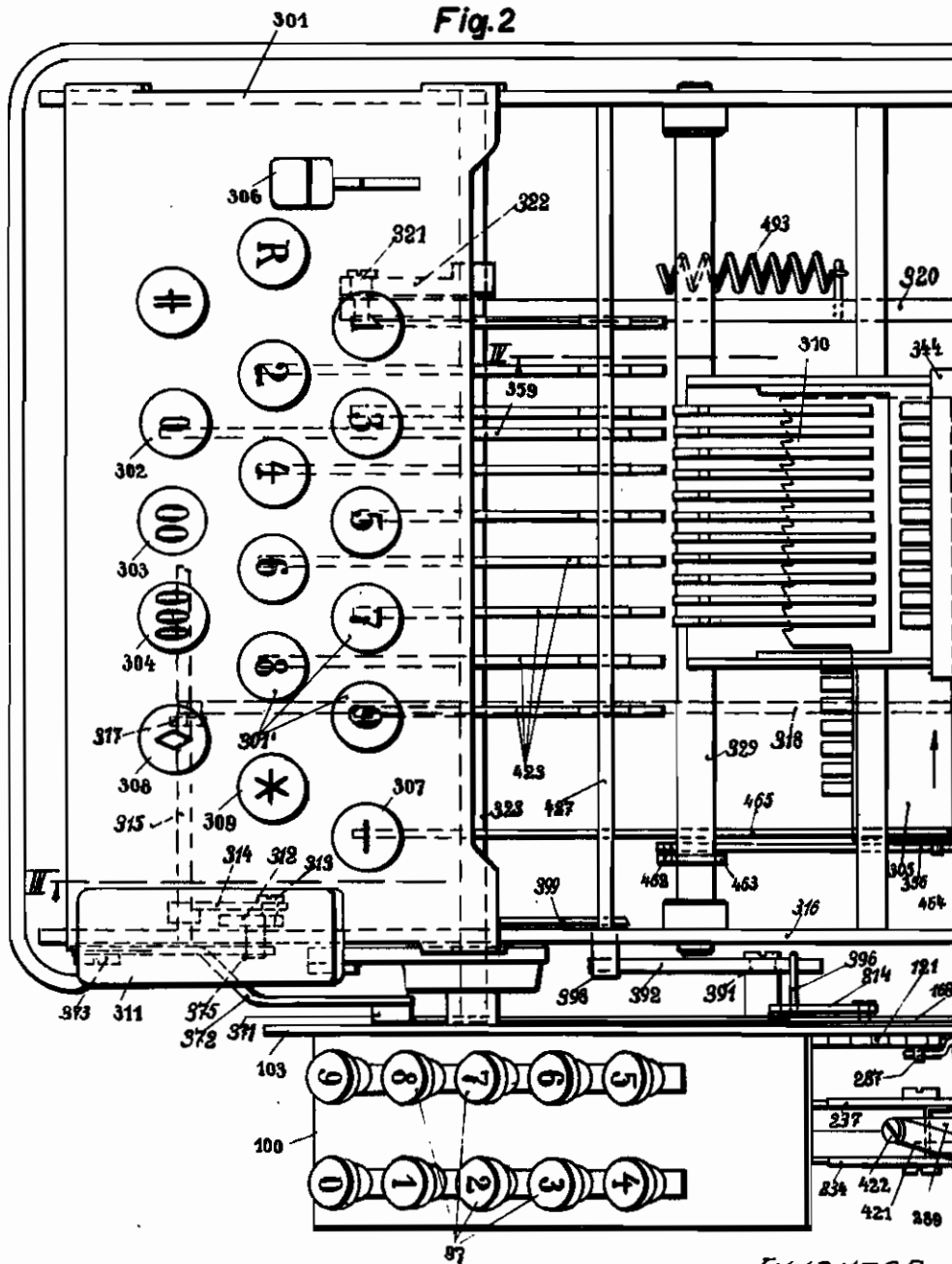

By

INVENTOR
K. B. W. KIEL
John Chid
ATTORNEY

PUBLISHED

JULY 13, 1943.

BY A. P. C.

K. B. W. KIEL

ADDING MACHINE

Filed Aug. 12, 1938

Serial No.

224,630

12 Sheets—Sheet 4

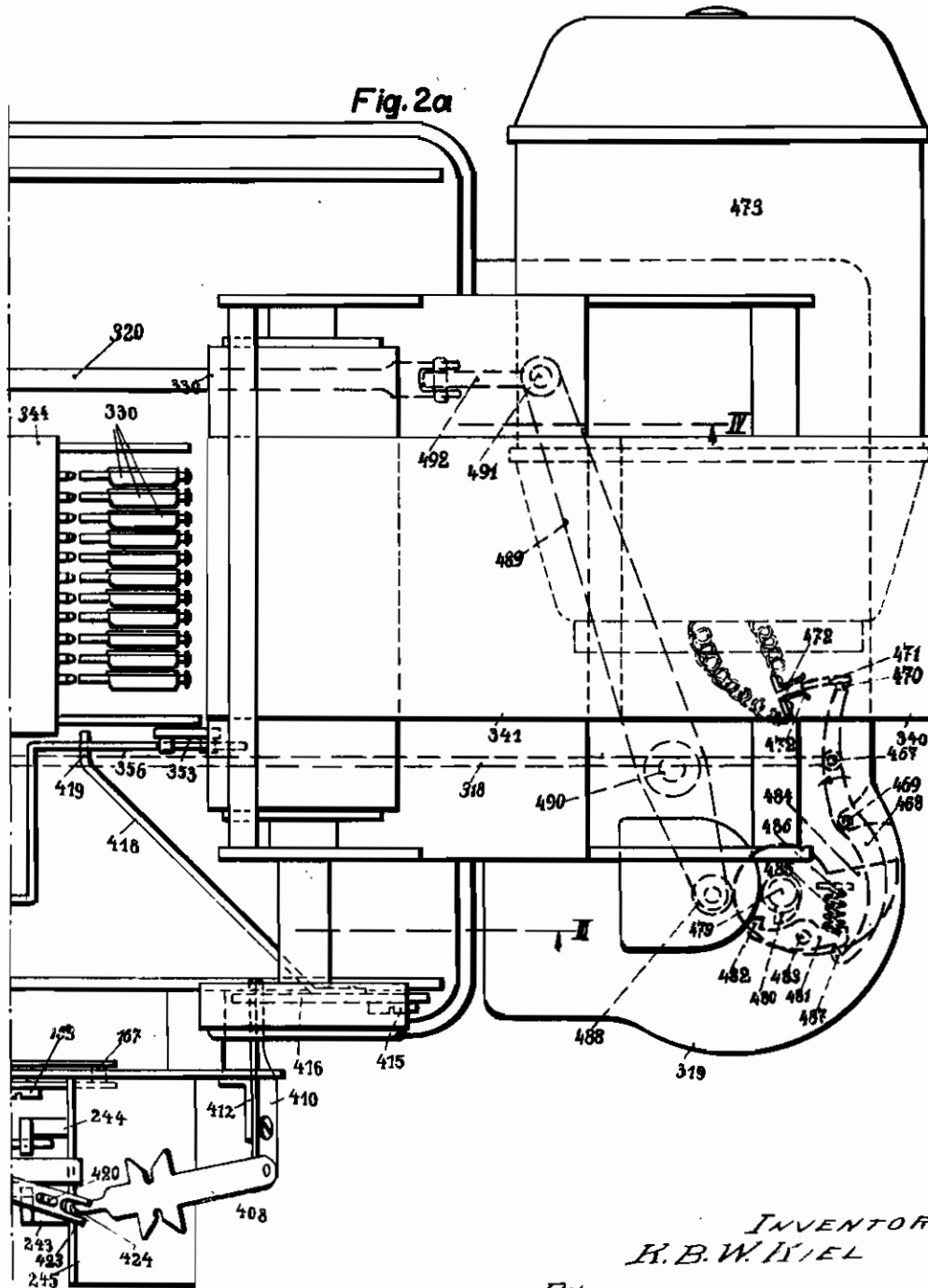

INVENTOR
K. B. W. KIEL

BY *John E. Kind*
ATTORNEY

PUBLISHED
JULY 13, 1943.
BY A. P. C.

K. B. W. KIEL
ADDING MACHINE
Filed Aug. 12, 1938

Serial No.
224,630
12 Sheets-Sheet 5

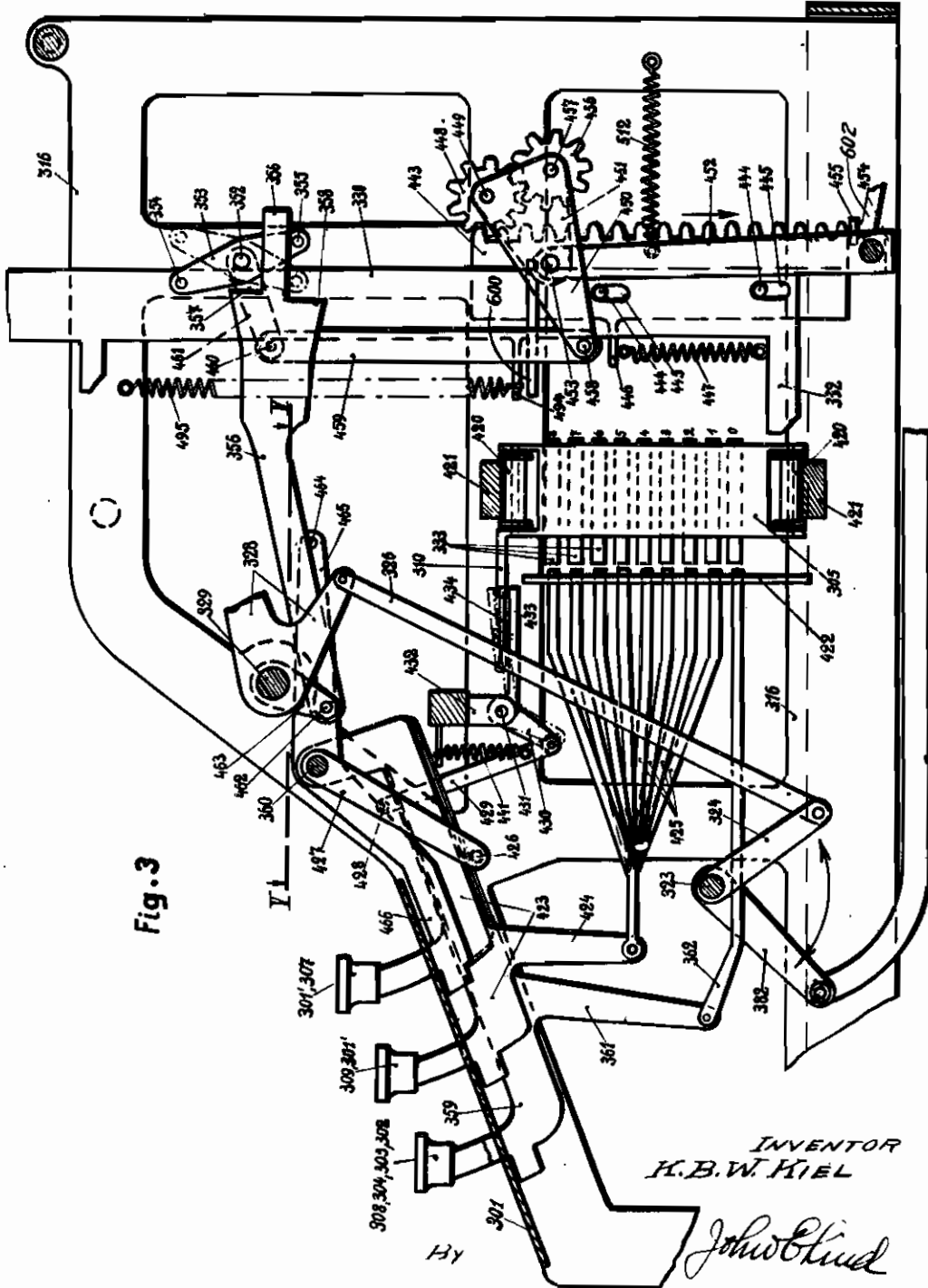

Fig. 3

INVENTOR
K. B. W. KIEL

By *John O. Lind*
ATTORNEY

PUBLISHED
JULY 13, 1943.
BY A. P. C.

K. B. W. KIEL
ADDING MACHINE
Filed Aug. 12, 1938

Serial No.
224,630
12 Sheets—Sheet 6

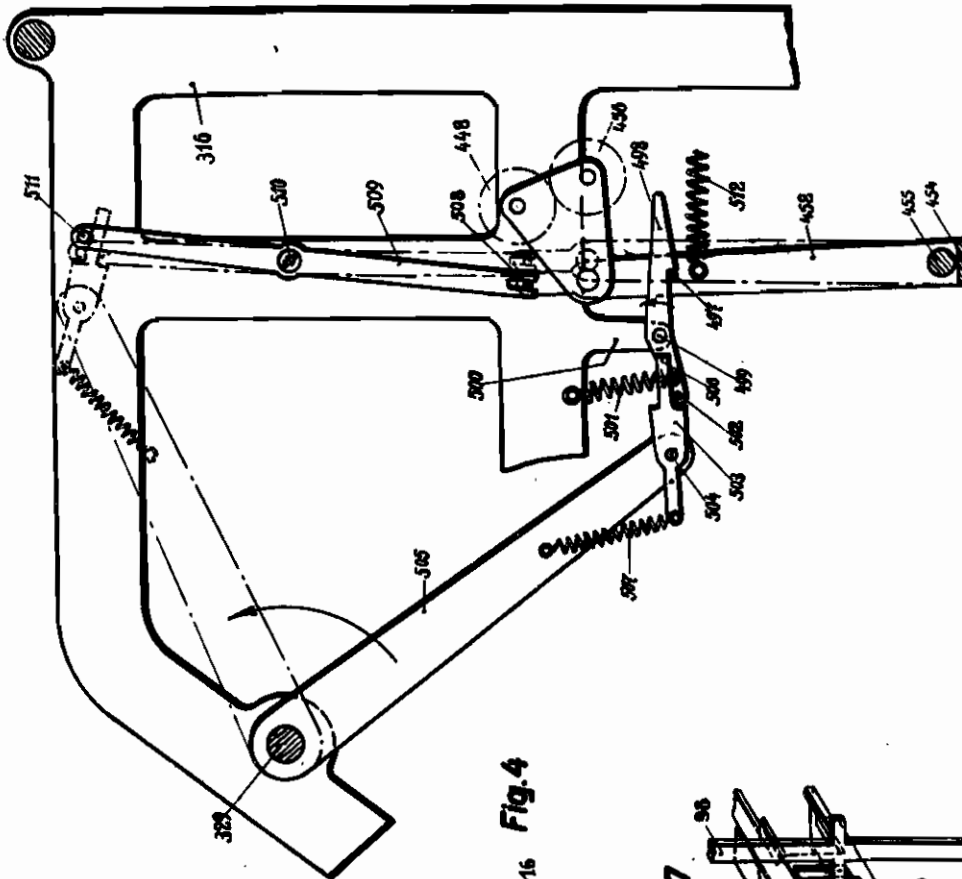

Fig. 4

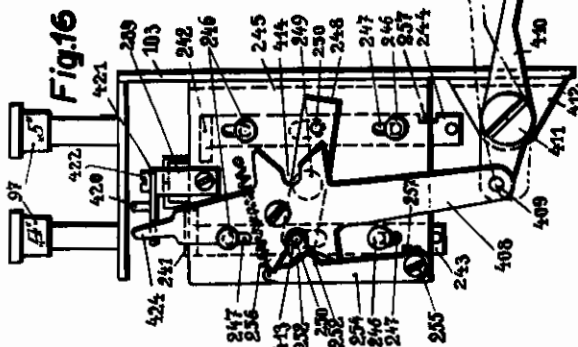

Fig. 16

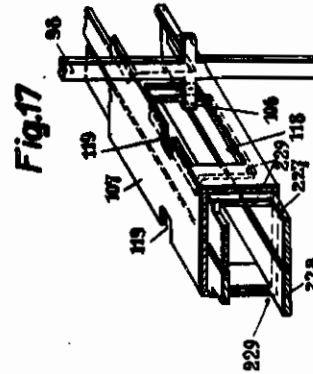

Fig. 17

By

INVENTOR
K. B. W. KIEL
John E. Kluid
ATTORNEY

PUBLISHED

JULY 13, 1943.

BY A. P. C.

K. B. W. KIEL

ADDING MACHINE

Filed Aug. 12, 1938

Serial No.

224,630

12 Sheets-Sheet 7

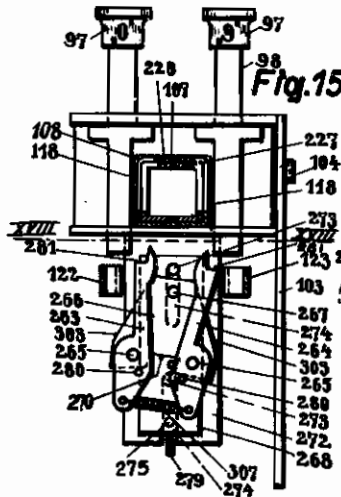
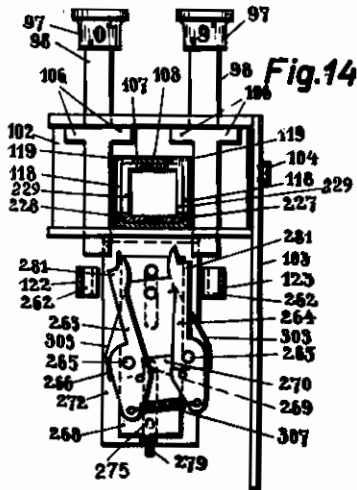

Fig. 18

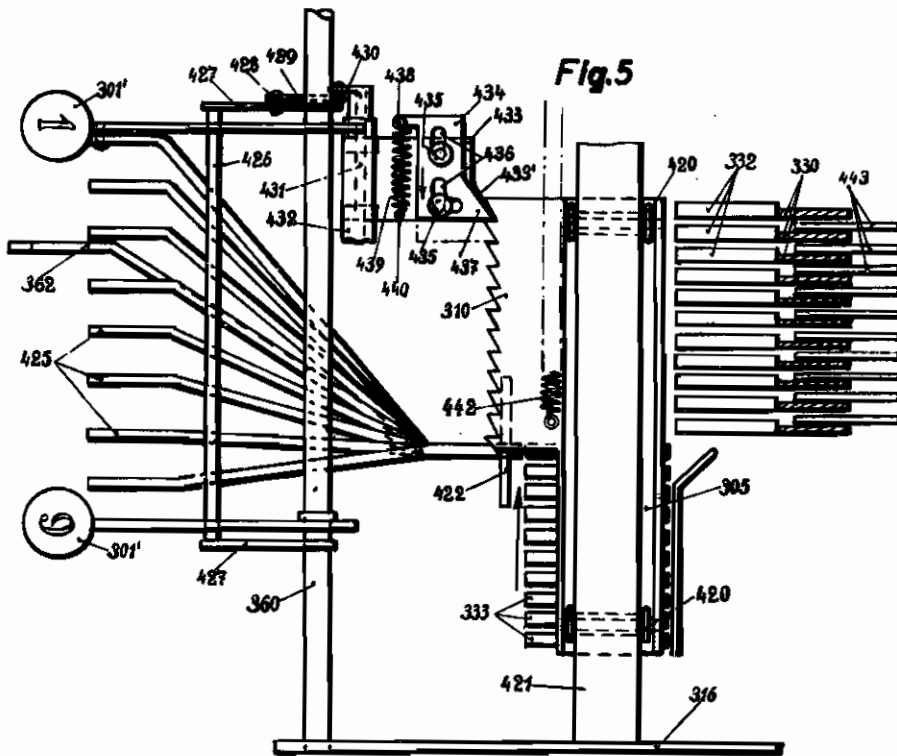
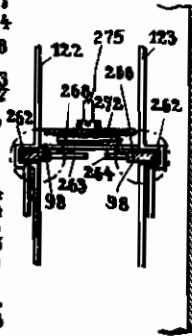

Fig. 5

INVENTOR
K. B. W. KIEL

BY

John Chuid

ATTORNEY

PUBLISHED
JULY 13, 1943.
BY A. P. C.

K. B. W. KIEL
ADDING MACHINE
Filed Aug. 12, 1938

Serial No.
224,630
12 Sheets-Sheet 8

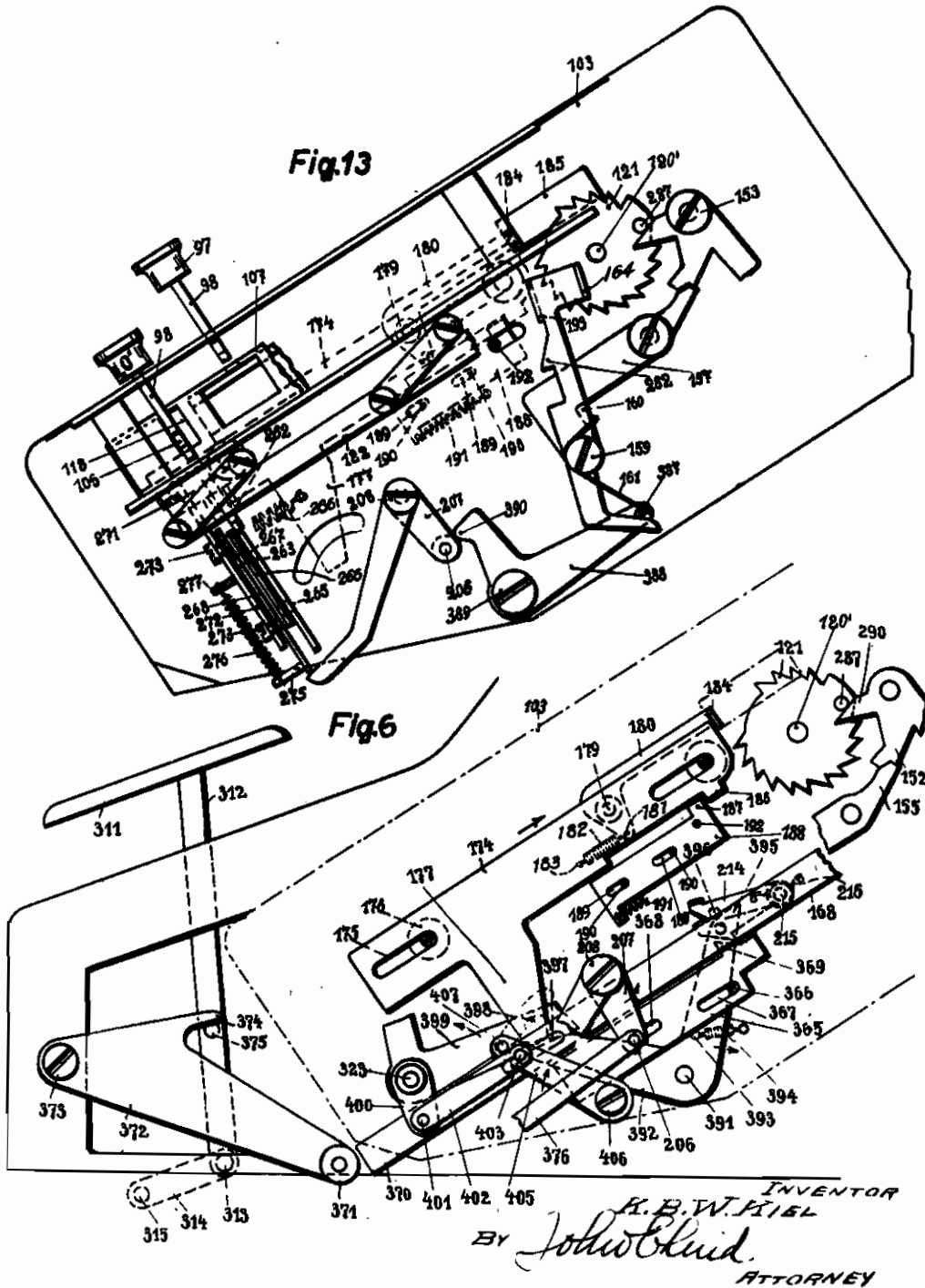

PUBLISHED

JULY 13, 1943.

BY A. P. C.

K. B. W. KIEL

ADDING MACHINE

Filed Aug. 12, 1938

Serial No.

224,630

12 Sheets—Sheet 9

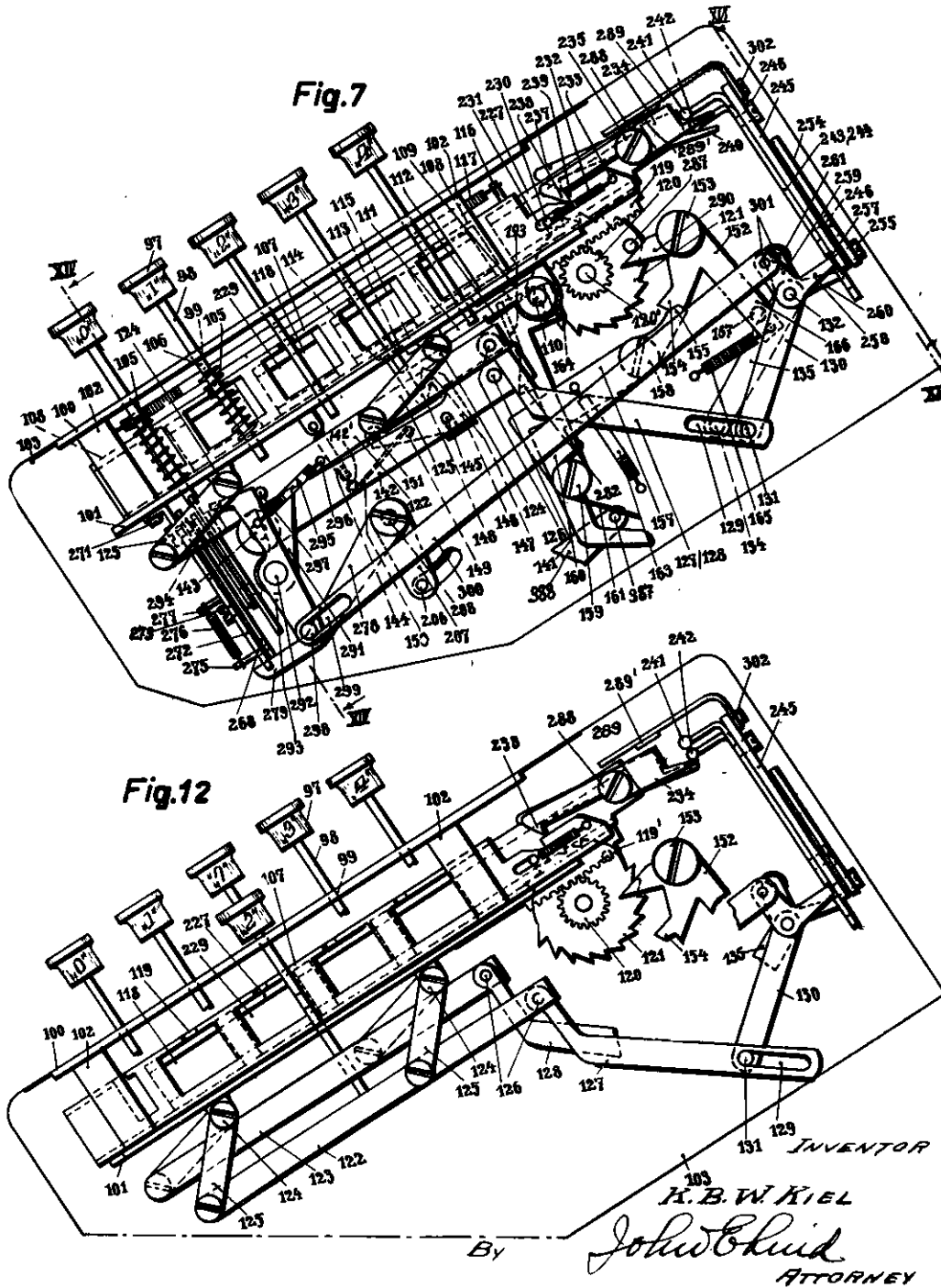

PUBLISHED
JULY 13, 1943.
BY A. P. C.

K. B. W. KIEL
ADDING MACHINE
Filed Aug. 12, 1938

Serial No.
224,630
12 Sheets-Sheet 10

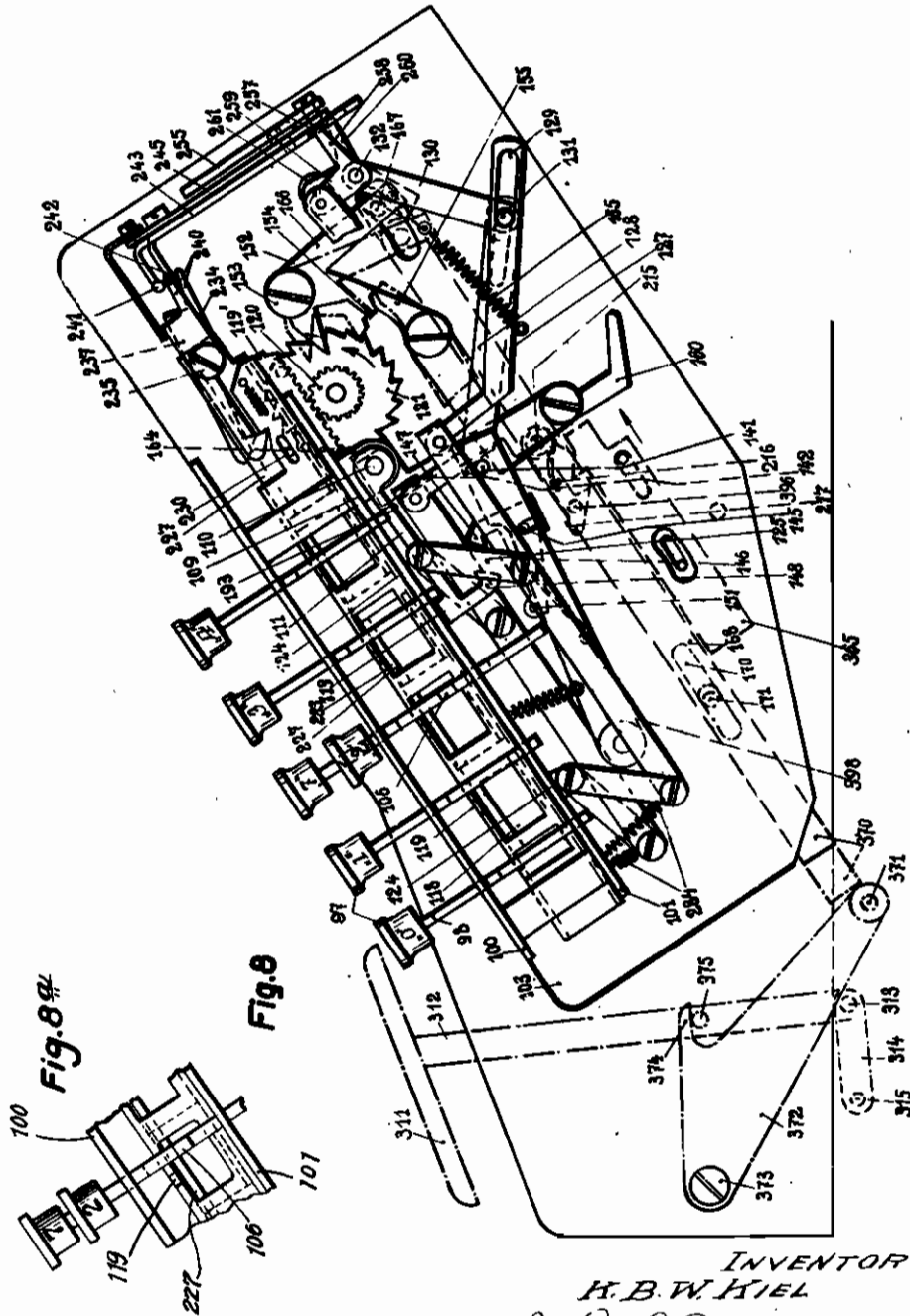

INVENTOR
K. B. W. KIEL
BY *John Chuid*
ATTORNEY

PUBLISHED
JULY 13, 1943.
BY A. P. C.

K. B. W. KIEL
ADDING MACHINE
Filed Aug. 12, 1938

Serial No.
224,630
12 Sheets-Sheet 11

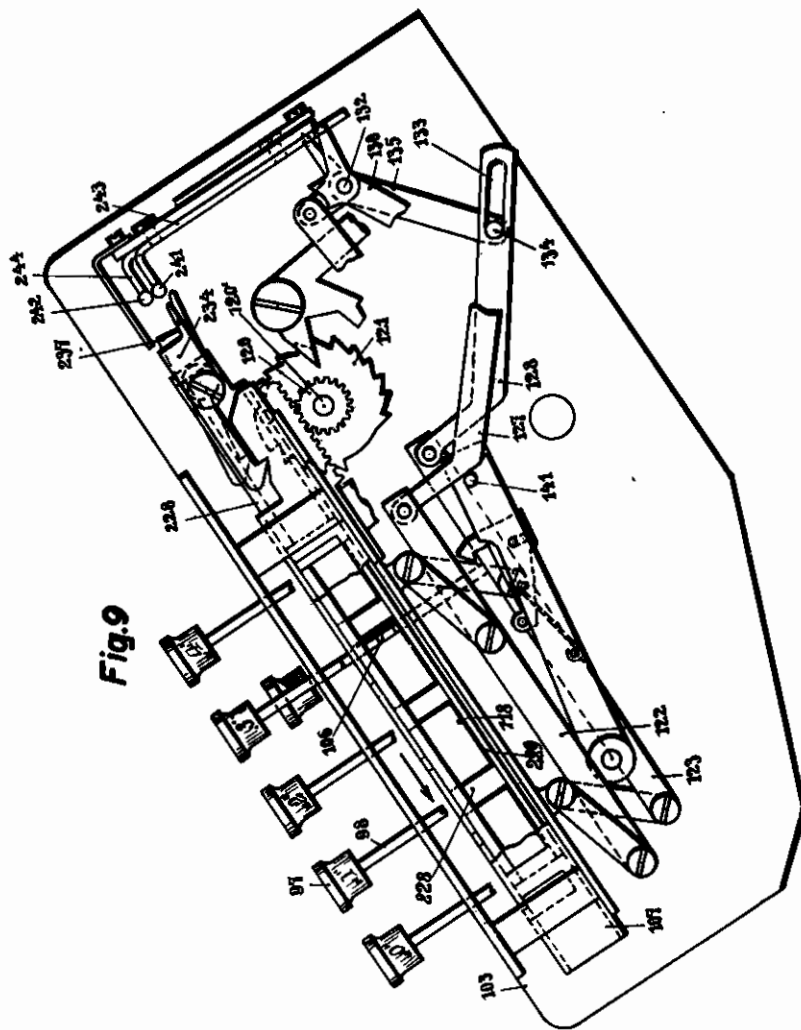

Fig. 9

INVENTOR
K. B. W. KIEL

By

John O. Kluid

ATTORNEY

PUBLISHED
JULY 13, 1943.
BY A. P. C.

K. B. W. KIEL
ADDING MACHINE
Filed Aug. 12, 1938

Serial No.
224,630

12 Sheets-Sheet 12

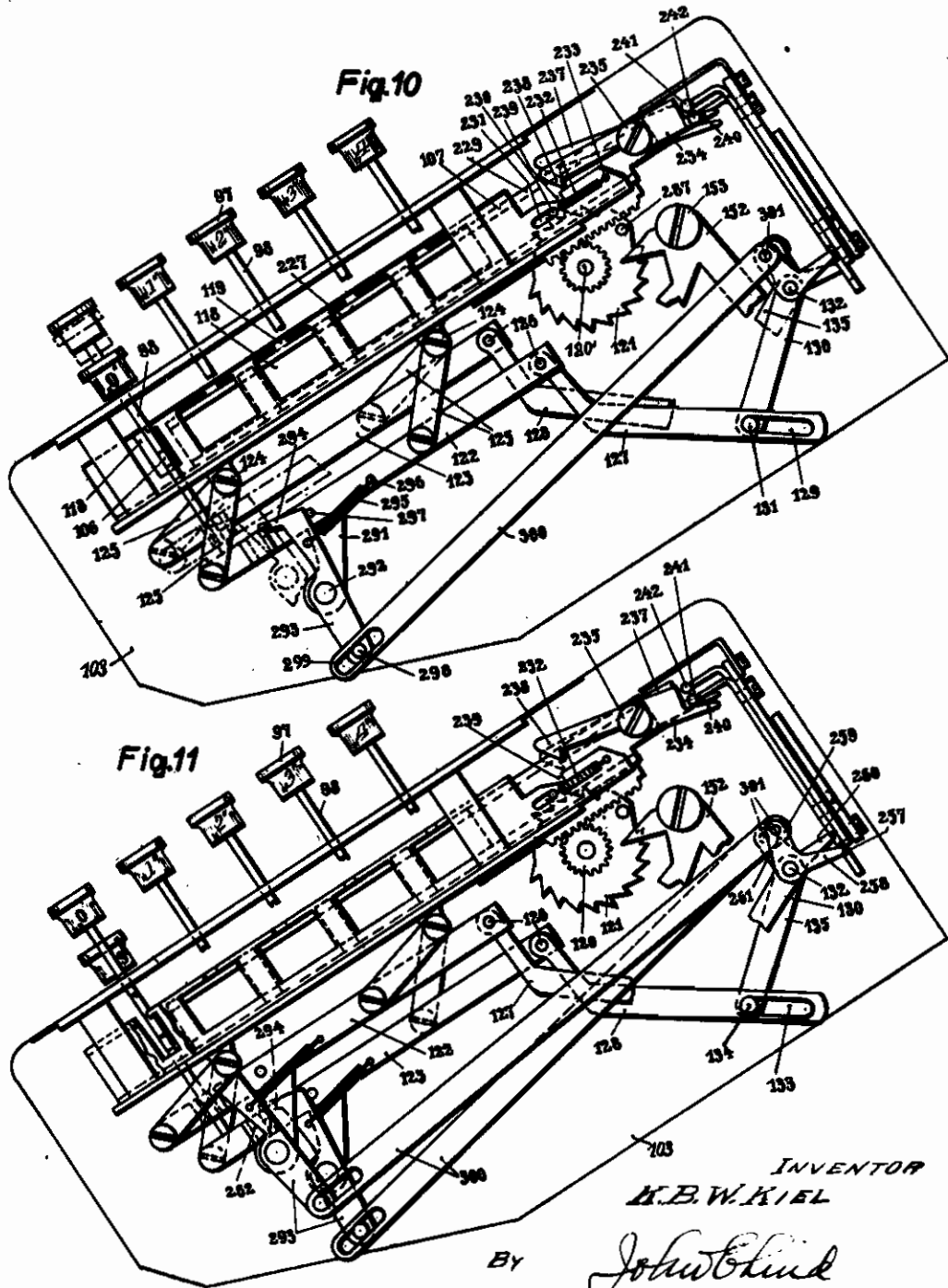

INVENTOR
K. B. W. KIEL

By *John Blind*
ATTORNEY

ALIEN PROPERTY CUSTODIAN

ADDING MACHINE

Karl Berthold Wilhelm Kiel, Glashutte, Germany;
vested in the Alien Property Custodian

Application filed August 12, 1938

This invention relates to an adding machine with which is combined a multiplying arrangement capable of operating by shortened multiplication.

It is well known that multiplying can be done on adding machines by adding repeatedly the value set up as by actuating the repeat key and pressing down the motor key repeatedly. This method of operating, however, requires keen attention on the part of the operator, and experience has demonstrated that it is not carried out without calculating errors. In order to overcome these difficulties a so-called multiplier setting mechanism has been provided on the adding machine and by means of this the "repeat" additions were carried out automatically by pressing a suitable key.

However, this did not provide means for utilizing the adding machine for large scale multiplication operations, because the adding machine, as a result of the oscillatory movements of its principal parts, was too slow in operation for the purpose intended.

It is an object of the present invention to adapt an adding machine notwithstanding its relatively slower operation for use as a multiplying machine. The multiplier setting mechanism according to the present invention is arranged so that the values above 5 are calculated by shortened multiplication.

A further object of the invention is to provide a particularly simple construction wherein a shifting member actuated by the multiplier setting mechanism acts on the stem of the motor key by means of an intermediate member such as a lever or the like.

A further object of the invention is to provide an arrangement wherein the shifting means of the multiplier setting mechanism, which determines whether addition or subtraction is to be used, is connected with the means of the adding machine for reversing the calculating mechanism gears so as to set them for the desired addition or subtraction.

The accompanying drawings show an example of the invention. Referring to the drawings:

Figure 1 is a partial side view of the invention with the cover plate removed.

Figure 1a is a continuation of the view shown in Figure 1 and to the right thereof.

Figure 2 is a partial plan view with a portion of the cover plate removed.

Figure 2a is a continuation of the view in Figure 2 and to the right thereof.

Figure 3 is a cross sectional view taken on the section line III—III of Figures 2 and 2a with parts broken away and omitted for greater clarity.

Figure 4 is a cross sectional view taken on the section line IV—IV of Figures 2 and 2a looking in the direction of the arrows and with portions omitted for greater clarity.

Figure 5 is a horizontal cross sectional view taken on the section line V—V of Figure 3 with portions omitted for greater clarity.

Figure 6 is a cross sectional view illustrating particularly the connections with the motor key and the means for securing the step-by-step return motion of the ratchet wheel.

Figure 7 is a cross sectional view of the multiplier setting mechanism in initial position.

Figure 8 is a cross sectional view similar to Figure 7 but with some of the parts omitted for greater clarity illustrating the position of the parts when the multiplier setting key "2" is depressed.

Figure 9 is a view similar to Figure 7 with parts omitted for greater clarity illustrating the position assumed by certain elements when the multiplier setting key "6" is depressed.

Figure 10 is also a view similar to Figure 7 with parts omitted for greater clarity illustrating the position taken by some of the parts when the multiplier key "0" is depressed.

Figure 11 is a view similar to Figure 7 with some of the parts omitted for greater clarity illustrating the position assumed by various elements when the multiplier setting key "9" is depressed.

Figure 12 is also a view similar to Figure 7 with parts omitted for greater clarity illustrating the position taken by some of the elements when the multiplier setting key "2" is depressed with the controls however in a different position from that shown in Figure 8.

Figure 13 is a partial cross sectional view similar to that shown in Figure 10 with parts omitted for greater clarity and other cooperating parts inserted in order to more clearly show the operation between such cooperating parts.

Figure 14 is a cross sectional view taken on the section line XIV—XIV of Figure 7 looking in the direction of the arrows and illustrating the particular controls for the multiplier setting keys "0" and "9".

Figure 15 is a similar view to Figure 14 showing the parts in a different position.

Figure 16 is a cross sectional view taken on the section line XVI—XVI of Figure 7 and looking in the direction of the arrows illustrating

particularly the control means for the reversing of the calculating or counting gears and the control for the means governing the step by step movement of the ratchet shifting means.

Figure 17 is a partial perspective view illustrating the construction of a control tube and cooperating U-shaped bars determining the step-by-step movements to be given to the ratchet shifting wheel in accordance with the particular multiplier setting key depressed, and

Figure 18 is a cross sectional view taken on section line XVIII—XVIII of Figure 15.

The invention is illustrated and described as based upon the well known "Astra" type of adding and subtracting machine, such as shown in Patent No. 1,897,932 issued Feb. 14, 1933.

The adding and subtracting machine

Arranged on the keyboard 301 of the adding machine in well known manner are the nine keys 301', which are designated "1"-"9." The zero keys 302, 303 and 304 cooperate in well known manner with the setting piece carriage 305. "R" designates the repeat key through the setting of which the well known clearing mechanism acting on the carriage is disconnected. 306 designates the clearing lever for the setting mechanism. The key 307 having the minus sign (-) sets the machine for subtraction, that is, by pressing such key, the means for reversing the calculating or counting gears is actuated and the calculating mechanism operates subtractively. 308 designates the key by which the intermediate total is determined and 309 designates the total key.

The setting piece carriage 305 is provided below and above with two rollers 420 by means of which it runs on two guide rails 421 attached to the machine frame. The carriage is provided with a plurality, in the present example ten, vertical rows of setting pins 333, each row comprising nine pins, so that the carriage of the present exemplary embodiment carries ninety such pins. The setting pins are set by means of the keys 301' or 302, 303 and 304.

Key 302 is attached to a key lever 359 which is journaled on a shaft 360 attached to the machine frame. The lever 359 is provided with a downwardly extending arm 361 with which a rod 362 is engaged. The right end of rod 362 is slidably guided longitudinally in a perpendicular bracket plate 422 attached to the machine frame. The end of rod 362 extends within range of the lowermost sliding setting pin 333, which corresponds to the "0" value. The keys 303 and 304 act in a similar manner on the rod 362.

The keys 301' are attached to the suitably formed nine key levers 423, which are also journaled on the shaft 360. Each key lever 423, except that which carries the "9" key, has a downwardly extending arm 424, each connected with a rod 425. The rods 425 are held so as to be longitudinally slidable at their free ends in the guide plate bracket 422.

The rod 425 which is connected with the key 301' designated "1," acts on the second row of sliding setting pins 333 which correspond to the value "1." The key 301' designated by "2" cooperates with the rod which is coordinated with the third row (from the bottom) of sliding setting pins 333, and so on. Keys 302 and 301' also cooperate with an escapement mechanism for the lateral movement of the carriage 305, which comprises the following construction.

The key levers which carry the corresponding

keys 301' and 302 engage by their lower surfaces a rod 426, whose ends, as shown in Fig. 5 are attached to two levers 427. The levers 427 are attached to the shaft 360, which is rotatably journaled in the machine frame. One lever 427 is connected by a pin 428 to one end of a link 429 which at the other end, engages a lever 430. Lever 430 is attached to a shaft 431 rotatably journaled in a bearing 432 attached to the machine frame.

A plate 433 is also attached to shaft 431 and carries a shift tooth 433'. (See Fig. 5.) Another plate 434 is slidably mounted on plate 433. For this purpose, the two attaching screws 435 engage through corresponding slots 436 of plate 434. Plate 434 is provided with a shift tooth 437 corresponding to the shift tooth 433'. Also engaged with plate 434, at 438, is a traction spring 439 which is attached at 440 to plate 433. This spring tends to move plate 434 in the direction of the arrow in Fig. 5. According to Fig. 5, this plate is prevented from movement by its tooth 437 engaging in a rack 310 attached to the carriage.

If one of the keys 301' or 302 are depressed not only is the corresponding setting pin 333 of the vertical pin row in front of the rods 425 moved to the right from the position shown in Fig. 3, but also, at the same time, by means of the elements 426-430, the plate 433 is swung, against the traction of a spring 441, into the dotted line position of Fig. 3. In this swinging movement of the plate 433, the tooth 433' passes into the denture of rack 310, while tooth 437 is released therefrom and moves to the dotted line position of Fig. 5 through the traction of spring 439.

If the depressed key is released, then, through the traction of the spring 441, plate 433 again swings downwardly and the tooth 433' passes out of the range of the denture of rack 310 and the spring urged tooth 437 simultaneously passes into the denture of rack 310. Under the pull of the stronger traction spring 442 engaged with the carriage, the carriage is moved in the direction of the arrow in Fig. 5 for the distance of one rack tooth and the plate 434 again assumes the position shown in full lines in Fig. 5. The carriage has thereby been moved the distance between adjacent rows of pins 333 since each rack tooth corresponds thereto.

Associated with carriage 305 is a number of type carrying bars 330, of which, as shown in Figs. 2 and 5, eleven are provided arranged in adjacent relationship. It is to be noted that ten of these bars carry the types "0"-"9," while the eleventh contains the symbols or signs. The individual types 331 are arranged slidably on the bars 330. Provided at the lower end of each type bar 330 is a projecting shoulder 332 which extends within range of the setting pins 333 slidably mounted in carriage 305.

The type bars 330 are also each provided with an arm 334 over which a common cross bar 335 engages. The bar 335 is carried by a slide 336 which is moved upwardly by means of a link 337 connected thereto and by a control lever 338, connected to link 337 when the machine is operated. In this manner all the type bars 330 are released, so that they can pass upwardly under the pull of the traction springs 495 engaged with projections 494 thereon until the corresponding shoulders 332 contact the extruded setting pins 333 of the pin row coordinated therewith.

A rack 443 is associated with each type bar 330. Each rack 443 is provided with two pins

444 engaging in slots 445 of the bars 330. Each rack is provided with an arm 448 to which a traction spring 447 is engaged. The other end of spring 447 is attached to the bar 330 with which the rack 443 is associated. The spring 447 tends to move the rack 443 relative to the bar 330 in the direction of the arrow in Fig. 3.

The calculating mechanism gears and reversing means therefor

Coordinated with the racks is a calculating mechanism consisting of a suitable number of counting gear wheels 448. The gears 448 are journaled on a shaft 449, which is attached in the two parallel plates 450 and 451. The two plates are pivoted to two levers 452 by pins 453, and the levers 452 are disposed at both sides of the set of bars 330. The levers 452 are interconnected at the bottom by a crossbar 454 and are mounted oscillatably on a trunnion 455 attached to the machine frame.

Each gear 448 of the calculating mechanism is engaged with a reversing gear 456. The gears 456, which have the same number of teeth as the gears 448, are journaled on a shaft spindle 467 which is attached to the two frame plates 450 and 451. Engaged with the lower end of the plate 450, at 456, is a link 459 which is connected by a pivot pin 460 to a lever arm 461. The lever arm 461 is fixed to the shaft 352 journaled in the machine frame 316. A plate 353, which is provided at both diametrically opposite ends with pins 354 and 355 is fixed to shaft 352. By setting or pivoting plate 353 into the dotted line position of Fig. 3, the plates 450 and 451 are swung about the pins 453 so that the calculating mechanism gears 448 unmesh from and the reversing gears 450 mesh with the racks 443. In this manner a certain predetermined movement of the racks in one direction with respect to the calculating mechanism gears 448 is reversed to the opposite direction and brings about the opposite method of calculation, that is, the value based on the magnitude of the rack movement is not added, but subtracted.

The plate 353 is set in one or the other terminal position by means of a plate 356 which is provided with the two shoulders 357 and 358. Plate 356 is journaled at one end on a pin 462 provided on the end of a lever arm 463. The lever arm 463 is attached to a shaft 329 which is journaled in the machine frame 316. Also mounted on shaft 329 is a bellcrank lever 328 which is connected by a link 326 to a lever arm 324 attached to the main drive shaft 323. Through a means hereinafter described, the main shaft describes an oscillatory movement which is transmitted through the link 326 into a similar movement of the lever 463 connected to shaft 329.

A pin 464, attached to an arm 465, engages under the plate 356. Arm 465 is an extension of the key lever 466, which is journaled on shaft 360 and which carries the key 307 bearing the minus (-) sign. It is apparent that by pressing on the key 307, through the pin 464 the plate 356 is swung upwardly so that the shoulder 357 comes in front of the pin 354.

If the plate 353 was previously in the position shown by the full lines in Fig. 3, then, in the outward swinging of the lever 463, the plate 353 will be swung by the plate 356 into the dotted line position in Fig. 3 and the calculating mechanism gears 449 and 456 thus moved to the subtracting position.

The motor drive and coupling means

The keyboard 301 is also provided with the motor key 311 carried by the rod 312. The lower end of rod 312 is pivoted at 313 to a lever 314 which is fixed to shaft 315 journaled in the machine frame 318. Connected to shaft 315 is another lever arm 317 to which a rod 318 is connected. Rod 318 is connected by a pivot pin 487 to the lever 468 which actuates the clutch and contact devices. Lever 468 is journaled at 469 in the housing 310.

Attached to one end of the lever 468, with an interposed insulating member 470, is an electrical switch member 471 which cooperates with the two spring pressed contacts 472. The springs of the contacts are in the circuit of an electric motor 473, on the shaft 474 of which is attached a worm gear 475 which meshes with a worm gear 476. Worm gear 476 is attached to a vertical shaft 479 journaled in bearings 477 and 478 in the housing 310.

Attached to the shaft 479 is a ratchet tooth 480 with which the nose 482 of pawl 481 cooperates. Pawl 481 is mounted by means of the pivot pin 483 on a cam disc 484 which is freely rotatable on the shaft 479. A pressure spring 485, supported on a projection 486 on the cam disc 484 acts on the pawl 481. Cooperating with the free end of the pawl 481 is the hook end 487 of the lever 468, so that when the lever 468 assumes the position of Fig. 2a the hook end 487 holds the nose 482 of the pawl 481 out of engagement with the ratchet tooth 480.

Cooperating with the cam disc 464 is a cam roller 468 mounted on one arm of a double armed forked lever 489 pivoted on pin 490 provided in the housing 319. The other arm of lever 489 is pivotally connected by pin 491 to a link 482 which in turn is pivotally connected to rod 320 at one end thereof. The other end of rod 320 is pivotally connected by pin 321 to lever arm 322 fixed to main shaft 323.

Thus, if the motor key 311 is depressed, then, by means of the levers 314 and 317, the rod 318 is moved to the left as shown in Figs. 1, 1a, 2 and 2a and the lever 468 is swung in the direction of the arrow in Fig. 2a whereby, through the switch member 471, the circuit for the electric motor 473 is closed and at the same time the hook end 487 releases the pawl 481, so that its nose 492 engages ratchet tooth 460.

In the ensuing rotation of shaft 479 by motor 473, the cam disc 484 is carried along and through the action of the double armed lever 489, the rod 320 is at first drawn to the right from the position shown in Figs. 1, 1a, 2 and 2a, thereby rotating the main shaft 323 counter-clockwise. The spring 493 connected at one end to the frame and at the other end to rod 320 maintains roller 468 in contact with cam disc 484 and returns the rod 320 to its initial position thereby rotating shaft 323 clockwise and returning the members connected therewith.

It is to be noted that during the swinging movement of the lever arm 322 in the direction of the arrow in Fig. 1, the slide 336 is moved upwardly, so that the bars 330 are released and can pass upwardly due to the traction of the springs 495 engaging projections 494, until the projecting shoulders 332 strike against an extended sliding pin 333. In this upward movement of bars 330 the types 331 are carried into the range of the printing device, which consists substantially of the platen 339 over which the paper strip 341 coming from the roll 340 runs.

The ribbon 496 is disposed in front of the platen 339.

The calculating gears control

It is to be noted primarily that during the upward movement of the bars 330 the calculating mechanism gears 448 and 450 must not operate. On the contrary, the calculating gears are to be swung into operative position on the return of the rods 330 to the initial position. For this purpose the control means shown particularly in Fig. 4 are provided.

Fixed on a lever arm 452 is a pin 497 which cooperates with a latch 400. The latch is journaled at 499 to a frame extension arm 500 and is subjected to the action of a traction spring 501 which always tends to hold latch 499 engaged with the pin 497. The free end of latch 400 is provided with a pin 502, with which a toggle impact lever 503 cooperates. The toggle lever is pivoted at 504 to the free end of swinging lever arm 505 attached to shaft 329. In the initial position of the machine, the lever arm 505 assumes the position indicated in Fig. 4 by the full lines, and the finger-like extension 508 of the lever 503 is applied, through the pull of the engaging traction spring 507, against the pin 502. However the spring 507 is so weak that it can not overcome the action of spring 501.

Mounted on the lever 452, on which pin 497 is provided, and by means of a suitable extension, is another pin 508 over which the forked end provided on one arm of a double armed lever 509 engages. The lever 509 is journaled by means of the pin 510 on the machine frame 316. The free end of lever 508 is provided with a pin 511 which extends into the movement range of the toggle impact lever 503 carried by lever arm 505.

If, by actuating the motor key, the main shaft 323 is rotated counter-clockwise, then, at the same time, by means of the link 326, the shaft 320 is rotated counter-clockwise and the lever arm 505 is swung out in the direction of the arrow in Fig. 4. In this swinging movement, the lower shoulder of the toggle lever 503 strikes against the pin 502 and the latch 499 describes a swinging movement in the direction of the arrow in Fig. 4. Through this swinging movement, the pin 497 is released from the latch catch so that the levers 452 together with the calculating mechanism gears 446 and 456 can swing through the traction of spring 512 to the right as shown in Fig. 4, so that the gears of the calculating mechanism can move outside the range of the racks 443. After the lever 503 has passed over the pin 502, the latch 499 is again drawn into the operative position, wherein the end of latch 499 is applied on the pin 497. Thus, immediately after the beginning of the upward movement of the bars 330, the calculating mechanism gears are swung into the inoperative position.

When the lever arm 322 reaches its extreme right end position, the lever arm 505 assumes the dotted line position of Fig. 4, in which position the finger-like extension 506 is applied against the pin 511 of the double armed lever 509 which is in the dotted line position of Fig. 4 corresponding to the swung out position of the levers 452. At the beginning of the reverse or return rotation of the shaft 320, and therefore before the downward movement of the bars 330, the upper shoulder of the toggle impact lever 503 strikes against the pin 511 and the double armed lever 509 is swung back into the position shown in full lines in Fig. 4.

In this swinging movement of the lever 508,

pin 508 moves the levers 452 back to the initial position shown in full lines in Fig. 4. As soon as this initial position is reached, the latch 499 can again, due to the action of spring 501, lock the pin 497. This means, however, that while the bars 330 have been carried downwardly towards the initial position, the calculating mechanism gears 448 and 456 are in the position shown in Fig. 4 and in Fig. 3. While the bars 330 are moved downwardly, the calculating mechanism gears are shifted positively or negatively, according to whether the plate 353 has thrown gears 456 into mesh with racks 443 or not.

The printing mechanism

The printing mechanism which enters into operation when lever arm 505 assumes the dotted line position of Fig. 4 operates in the following manner.

It is first to be noted that the pin-like intermediate members 343, shown in Fig. 1, are opposite the ribbon 496. The hammer levers 345, mounted oscillatably on the common shaft 346, cooperate with the pin-like intermediate members, which are guided axially slidable in the support 344 and are held by the springs 343' in the position shown in Fig. 1. The hammer levers 345 are subjected to the action of springs (not shown) which tend to swing them in the direction of the arrow shown in Fig. 1. The tensioning of the levers 345 is provided by the crossbar 347 which is attached to a lever 348. The latter is connected with a lever arm 349 in the slotted end 350 of which a pin 351 on one arm of the bellcrank lever 328 engages. The hammer levers are provided with the well known checks, stop or the like which, when the machine is actuated, and assuming that it is set for printing, are released, so that, under the pull of the springs engaged therewith the hammer levers contact the reinforced ends of the intermediate members 343 and move these so that they strike the type in front of them against the paper 341 with the ribbon 496 interposed.

The above well known arrangements, which serve for addition and subtraction, are coordinated with a multiplier setting mechanism, described hereinafter and by means of which shortened multiplication is possible.

The multiplier setting mechanism

The parts belonging directly to the multiplier setting mechanism are mounted on the base plate 103, which is attached by screws 363 and 364 to the machine frame 316 of the adding machine. The multiplier setting mechanism has ten multiplier setting keys 97 bearing the indicia "0"-"9" which are disposed at the right of the keyboard 301 of the adding machine.

Each of the keys 97 is mounted on a slide 98 (Figs. 7 and 11). The upper ends of the slides 98 are guided in slots 99 provided in a plate 100, while the lower ends are guided in corresponding slots of a plate 101. The latter is attached by cross members 102 to the upper plate 100.

The cross members 102 are fixed to the frame wall 103 by means of the screws 104. Encircling the lower end of the slides 98 are the springs 105 which urge the cross extensions 106 on the slides 98 against the lower side of the plate 100 and thus tend to hold the slides in the initial position.

The main shaft oscillation control

Disposed longitudinally slidable between the two rows of slides 98 is a rectangular tube 107

which is guided in suitable recesses 108 provided in the cross members 102. Attached to tube 107 is a bearing eye 109 which extends downwardly through a longitudinal slot provided in the plate 101. Journalled in the eye 109 by means of the pivot pin 110 is a pawl 111 with which a spring 112 engages and which tends to force the pawl upwardly. In the initial position shown in Fig. 7 the nose 113 of the pawl 111 is applied against the end 114 of the slot 115 provided in the plate 101. A traction spring 117 engages at one end the pin 116 provided on tube 107 and at the other end is attached to the front cross member 102. This spring urges tube 107 to the left as shown in Fig. 7. In the initial position shown in Fig. 7 the tube is locked by the pawl nose 113.

Tube 107 is provided on both sides with window-like recesses 118 (see Fig. 17) which connect with recesses 119 provided on the upper side of the tube. When the tube 107 is in the initial position, these recesses 119 are positioned exactly under the cross extensions 106 of the slides 99. It is to be noted that the recesses 118 are substantially only as wide as the thickness of the slides 99. Also, the window-like recesses 119 are so arranged with relation to the recesses 119 that, when the cross extensions 106 of the slides have entered the recesses 118 due to pressure on the keys, and the pawl 111 is released, the tube 107 may move for graduated lengths corresponding to the particular number value. Thus, the recess 118 coordinated with the "0" key permits movement of the tube for the distance x , the recess coordinated with the "1" key for the distance $2x$, and the recess coordinated with the "4" key permits a movement of the distance $5x$, etc. It is the same with the keys "5"-"9", but therein the movement corresponds to the complementary value. The recess coordinated with the "5" key thus permits a movement of the distance $5x$ and the recess coordinated with the "9" key permits a movement of the distance x .

A rack 118 is attached to the square tube 107 and engages gear 120. Gear 120 is mounted on pivot 120' on the base plate 103 and is connected to a ratchet shifting wheel 121. A one tooth shift or rotation of the wheel 121 will cause a movement of the rack 119 and consequently of the tube 107 for a distance x .

Associated with the lower ends of slides 98 are the two bars 122 and 123 which are carried link-parallellogram-like by the two members 125 journalled by pivots 124 to the bottom of the plate 101. Angular bars 127 and 128 (see Figs. 7 and 9) are pivoted at 126 to the ends of the bars 122 and 123. The bar 127 is provided with a slot 129 in which a pin 131 provided on a lever 130 engages. Lever 130 is oscillatably journalled on a pin 132 attached to the frame wall 103. The other bar 128 (see Fig. 11) is provided with a slot 133 into which a pin 134 extends. Pin 134 is attached to the lever 135 which is likewise journalled on pin 132.

Extending into the path of movement of bars 122 and 123 (see Fig. 9) is a pin 141 which is attached to a lever 142 pivoted at its front end to the frame 163. A traction spring 144 (see Figs. 7 and 8) is engaged at 143 with the lever 142, and the spring 144 tends to hold the lever 142 in the position shown in Fig. 7. Journalled on the lever 142, at 145, is a pawl 146 having a projecting shoulder 147 which engages a shoulder 148 provided on the pawl 111. A spring 150 engages the pin 149 on the pawl 148 and tends

to apply the pin 151 on the pawl 146 against the upper edge of the lever 142.

Cooperating with ratchet shifting wheel 121 is a plate 152 which is journalled oscillatably by pin 153 on the base plate 103.

Plate 152 is provided with a pawl 154 which is retained in the initial position shown in Figs. 1 and 7 by the locking extension 155, which extends into a recess provided in the pawl 154 of the plate 152. The locking extension is provided on the end of one arm of a double armed lever 157 which is oscillatably journalled by the pin 158 in the wall 103.

Journalled at the free end of the other arm of lever 157 by the pin 159, is a second lever 160 with which is engaged one end of a torsion spring 161 which, at the other end, is supported by a pin 387. Engaged with the lever 157, as shown, is the traction spring 163, which tends to hold the locking extension 155 in engagement with pawl 154. By means of the torsion spring 161, lever 160 is given a tendency to swing counterclockwise about pin 159. A lateral projection 164 provided at one end of the lever 160 is applied, in this manner, against the corresponding projecting pivot pin 110.

Plate 152 is subjected to the action of a traction spring 165 which tends to turn the plate clockwise. The spring 165 is connected to an arm 166 of the plate 152, and the arm 166 has a pin 167 connected to a bar 168 (Figs. 1 and 8). For this purpose the pin 167 engages through a slot 169 of the plate 103. Bar 168 is provided with a longitudinal slot 170 into which extends a pin 171 attached to the wall 103 (Fig. 8). The left end 370 of the bar 168 extends within range of a pin 371 (Fig. 1) which is on a lever plate 372. The latter is journalled by a pin 373 to the frame of the adding machine and provided with an extended finger 374 which engages over a pin 375 provided on the rod 312 of the motor key 311.

The pin 387 serving as a support for the spring 161 extends into the plane of movement of the angularly bent end of the lever 160. The pin 387 is attached to the end of a double armed lever 388 (Fig. 1) which is journalled by pin 398 on the frame plate 103. Lever 388 has a cam-like end 390 extending into the range of movement of a lever 207.

Pivoted to the frame plate 103, at pivot 391, (Fig. 6) is a V-shaped plate 392 to which, at 393, there is secured a traction spring 394 which tends to swing the plate in the direction of the arrow in Fig. 6. One end 395 of the plate 392 extends within range of a pin 396 provided on a pawl 214. The other free end 397 of the plate 392 extends into the range of movement of a pin 398 which is attached to one end of the bellcrank lever 399, which is carried by the main shaft 323 of the adding machine and in every oscillation swings from the initial position shown in Fig. 6 to the direction of the arrow and back.

The step by step actuation of ratchet wheel

Attached to shaft 323 is also a lever 400 at the free end of which, at pivot 401, there is secured a connecting rod 402 which is pivoted at the other end on the pin 403. Pin 403 is attached to a lever 405 which is oscillatably journalled by pin 408 on the plate 103. Provided also at the end of lever 405 is a pin 407 which engages through a corresponding slot of the supporting plate and extends within range of an arm 177 provided on a slide 174. The latter is longitudinally slidable

on plate 103 and for this purpose is provided with longitudinal slots 175 through which the screws 176 attached to the wall 103 project. Journalled on the bar 174 by pin 179 is a lever-like plate 180, at one end of which, at 181, there engages a traction spring 182 and the other end of the spring is attached, at 183, to the bar 174. The lever-like plate 180 is provided with a rectangular bent extension 184 which extends through a recess 185 provided in plate 103 within range of ratchet shifting wheel 121 (see Figs. 6 and 13).

Plate 174 is provided with a downwardly extending projection 186 (see Figs. 6 and 13) cooperating with the projection 187 of a sliding plate 188. The sliding plate is longitudinally guided by means of two slots 189 provided therein through which extend two pins 190 attached to the plate 103. The traction spring 191 engaged with plate 188 tends to move the plate to the right as shown in Fig. 6. Provided on the plate 188 is a pin 192 which extends into the plane of an abutting surface 193 provided on lever 160.

Pivoted to bar 168 by pin 215 is the pawl 214, with which the torsion spring 216 engages and which tends to apply the angular projection 217 of pawl 214 against the upper edge of the bar 168. (Figs. 6 and 8).

The carriage shift control

Coordinated with bar 168 is a sliding plate 365 which is provided with longitudinal slots 367 and 368. Engaging through the slot 367 is the screw pin 366 attached to the plate 103. Engaging through the other slot 368 is the pin 206, which is attached to a lever 207 and the lever 207 is journalled on a pin 208 attached to plate 103. The sliding plate 365 is provided with a shoulder-like projection 369 which cooperates with the correspondingly formed projection 395 of the pawl 214.

Means for aligning and disaligning recesses

Considering the case in which, through shortened multiplication in the immediately preceding decimal position, the next decimal position is greater by the value "1" than the value of the number, two U-shaped bars 227 and 228 are longitudinally slidably positioned (see Fig. 17) in the tube 107. These bars have recesses 299 corresponding to the recesses 118 in tube 107. Attached to each bar is a pin 230 (Fig. 7) which extends through a slot 231 provided in each side wall of the tube 107. Engaged with each pin is a traction spring 232, fastened at the other end, at 233, to the tube 107. The springs 232 thus tend to move the U-shaped bars 227 and 228 relative to the tube 107, in such direction that the pins 230 are applied against the right ends of the slots 231. In this position of the bars 227 and 228 relative to the tube 107, the operative edges of the recesses 118 are in operative relation to the window-like recesses 229 of the bars 227 and 228. These latter, however, as explained hereinafter, can, also, alternatively assume another position in which the corresponding edges of the window-like recesses 229 project forwardly of the edges of the window-like recesses 118, for a certain distance. This distance corresponds to the precedingly mentioned distance x , which at the same time represents a one step movement of the ratchet shifting wheel 121.

This alternative position is produced by a double armed lever 234 journalled on bar 227 by means of the screw pin 235 while the lever

237 is likewise rotatably attached by a screw pin 235 to the bar 228. The levers 234 and 237 are provided with hook-shaped projections 238 which alternately engage with corresponding recesses 239 provided on the tube 107. In the initial position according to Figs. 1 and 7 the hook-shaped projection 238 of the lever 234 lies in the coordinated recess 239, while the lever 237 is swung out so that its hook-shaped projection 238 is raised out of the range of its cooperating recess 239.

Setting control

The levers 234 and 237 are provided with extensions 240 which extend obliquely downwardly and into the range of the pin-like abutments 241 and 242. The abutment 241 is attached to the angular extension of a bar 243, while the abutment 242 is attached to the angular extension of a bar 244 (see Fig. 9). Bars 243 and 244 are vertically slidable on a plate 245 attached at right angles to the plate 103. For this purpose, screws 246 attached to bars 243 and 244 engage through slots 247 provided in plate 245. See Fig. 16. Journalled between the two bars 243 and 244, at pivot 248, is a double armed lever 248 having the pins 250 which engage the bars 243 and 244. The pins 250 project through the elongated recesses 251 provided in the plate 245. By means of this lever 248 the two bars 243 and 244 are positively interconnected so that when the one is moved downwardly the other is moved upwardly correspondingly. Lever 248 is held inoperative at both end positions. For this purpose, the pointed end 252 of the lever 248 cooperates with a gable-shaped extension 253 provided on a lever 254. The lever 254 is journalled by pin 255 on the plate 245 and is subjected to the traction of a spring 256.

Each bar 243 and 244 is provided with a recess 257. Extending into the recess 257 of the bar 243 is one arm 258 of a bellcrank lever having another arm 259. The bellcrank lever 258, 259 is connected with the lever 130 (Fig. 11). Engaging in the recess 257 of the bar 244 is an arm 260 of a similar bellcrank lever having another arm 281 and the bellcrank lever is connected to the lever 135.

As the lower ends of the key slides 98 extend into the range of the bars 122 and 123, on pressing a key 97 the lower end of the corresponding key slide contacts with the bar 122 or 123 and carries it into the position shown in Fig. 10 or Fig. 11. This causes the lever 142 to be swung downwardly and through the action of the pawls 146 and 111 releases the lock of the tube 107 and such tube can snap into a position determined by the particular cross extension 106.

Means for securing one decimal advance

Since, in certain cases, on pressing the key "0" and the key "9" (such as when on pressing the "0" key, shortened multiplication is not used in computing the preceding decimal position, and on pressing the "9" key shortened multiplication is used relative to the preceding decimal position) an advance is to be made for one decimal position, the following arrangement is provided.

The bars 122 and 23 (see also Figs. 15 and 18) are provided, in the range of the slides carrying the "0" and "9" keys, with bent portions 262, so that the key slides can pass by the bars 122 and 123 freely. Disposed in the range of these two key slides for the keys "0" and "9" are the double armed levers 263 and 264 (see also Fig. 14).

These two levers are journaled by means of pins 265 on a plate 266 which is journaled by means of a pin 267 on a sliding plate 268. The two end positions of the plate 266 are determined by a pin 269 mounted on the sliding plate 268 and this pin 269 extends into a rectangular recess 270 of the plate 266.

The sliding plate 268 is vertically slidable on a plate 272 attached by screws 271 to the plate 101 (see also Figs. 7, 13). For this purpose, the screws 273 attached to sliding plate 268 extend through corresponding slot-like recesses 274 provided in plate 272. Extending also through the lower guide slot 274 is the pin 275 attached to the slide 266, with which pin 275 there is engaged a traction spring 278 which is attached at the other end to the pin 277 provided on the plate 272. As shown on Figs. 7 and 14, the extension 279 on the lever 278 engages under the sliding plate 268. The lever 278 is connected with the above-mentioned lever arm 207 journaled on pivot 208.

Connecting the free lower ends of the levers 263 and 264 is the common traction spring 307 which tends to apply the pins 280 attached to said levers against the lower edge of plate 266 (see Fig. 15). The upper ends of levers 283 and 264 are provided with shoulders 281 which extend alternately within the range of the key slides coordinated therewith. In the position shown in Fig. 14, which corresponds to the initial position according to Figs. 1 and 7, the shoulder 281 of the lever 263 is in the range of the key slide 90 carrying the "0" key.

Provided on each of the bars 122 and 123 is a downwardly extending arm 291 (see Figs. 7 and 10) to which a double armed lever 293 is pivoted by means of the pin 292. These levers 293 are provided at their upper ends with tongue-like extensions 294 and the bent portions 262 of bars 122 and 123 are slotted in the range of such extensions (see Figs. 10 and 11). Engaged with each lever 293 is a traction spring 285 attached at the other end, at 296, to the bar 122 or 123 and which tends to draw the tongue-like extension out of the range of the coordinated key slide and apply the upper end of the lever 283 against an abutting pin 297 provided on each bar.

The lower free end of each lever 293 is provided with a pin 298. These pins 298 extend into slots 298 provided at the ends of the two bars 300. These two bars are connected at their other ends by pins 301 with the arms 259 or 281 of the bellcrank levers cooperating with recesses 257. By means of these bars 300 and the members 257 to 281, 243, 244 and 248, the levers 293 are so interconnected that only the tongue-like extension 294 of one lever 293 will always extend into the range of its cooperating key slide. In the initial position of Fig. 1 the tongue-like extension 294 coordinated with the key "0" would thus be carried out of range of the corresponding key slide, while the other tongue-like extension 294 extends in the range of the corresponding key slide of the key "9."

Pivoted on the pin 206 of lever arm 207 is a control bar 376 (Fig. 1) which, at the other end, is connected by a pin 377 with a lever arm 378. The latter is mounted freely rotatable on a shaft 380 journaled in a frame extension 379. Attached to the shaft 380 is a plate 381 which is engaged by a traction spring 382 attached at the other end, to pin 383, on the lever 378. This traction spring tends to apply the shoulder 384 of the plate 381 against the pin 383. A lever arm 75

385 is also attached on the shaft 380 and has a pin 306 extending into the plane of the extension 381 provided on the key lever 368.

Control of reversing mechanism

The reversing or shifting of the calculating mechanism, that is, its positive or negative, or additive or subtractive, connection with the rods 330, is initiated by the two slides 243 and 244 arranged on the wall 245 connected to the plate 103. These slides are controlled by the bellcrank arms 258 and 260. For this purpose, there is coordinated with the slides 243 and 244, a setting plate 408 (Fig. 16) which is pivoted by means of the pin 409 to the double armed lever 410. Lever 410 is journaled on the pivot pin 411 secured to plate 412 which is connected to plate 103.

The setting plate 408 is provided with two slot-like recesses 413 and 414 which open into two V-shaped openings. The pins 250 on the slides 243 and 244 are so constructed that they project with their ends into the range of movement of plate 408. If the plate 408 is in the position shown in Fig. 16, the coordinated pin 250 has passed into the recess 413. Inasmuch as the rods 243 and 244 are still in the initial position, lever 410 is in the position shown in Fig. 16. The end of a lever 416 (see also Fig. 1a) journaled at 415 on the machine frame contacts the free end of lever 410. Attached to lever 416, by rivets or the like 417, is an arm 418 having a bent end 419 which engages under the setting plate 356.

If, now, the slides 243 and 244 are shifted from the initial position according to Fig. 16, which takes place for example when one of the keys "5"—"9" is depressed, the slide 243 is moved downwardly and the slide 244 upwardly, and at the same time lever 410 is swung by the plate 408 so that the lever 410 causes the lever 416 to swing out in the direction of the arrow in Fig. 1a, that is, raises. The setting plate 356 is thereby raised to such extent that its shoulder 357 passes into the range of the pin 354.

If minus multiplications are desired it is only necessary, by means of the handle 420, to swing the plate 408 into the other end position, in which the pin 250 coordinated with the recess 414 is engaged. The handle 420 (Figs. 2 and 16) is mounted on a lever 421 journaled on pivot 422 on the frame bracket 289 and the forked end 423 of lever 421 engages the correspondingly reduced end 424 of the plate 408.

The operation

The operation is explained with reference to a calculating example:

$$12738 \times 26092$$

The multiplicand 12738 is first set up on the keyboard 301, beginning with the highest decade, thus the "1", then the "2", the "7", then the "3" and finally the "8", by depressing the corresponding keys 301'. Then, after the repeat key "R" has been actuated, beginning with the lowest digit, the multiplier is set up in the multiplier setting mechanism keys 87. The key designated "2" in the two key banks carried in plate 100 is next depressed.

By depressing key "2", the parts are carried into the position of Fig. 8 by contact of the slide 88 on the bar 122. Bar 122 contacts pin 141 and lever 142 is swung downwardly which, through the pawl 147, carries pawl 111 into the release position. The tube 107 is now moved by the spring 117 as far to the left as the cross exten-

sion 106 of the key slide associated with key "2" will permit. Since, in the initial position, the lever 234 is engaged with the notch 239 on tube 107, the U-shaped bar 227 is adjusted in tube 107 so that the edges of its window-like recesses 229 project beyond the corresponding edges of the window-like recesses 118.

Thus, as shown in Fig. 8, the corresponding cross extension 106 contacts with the edge of a window-like recess 228 of bar 227. The stroke or shifting space of tube 107 coordinated with key "2" is thus shortened one shift from three shift movements, so that the ratchet shifting wheel 121, as shown in Fig. 8, has been turned from the initial position in the direction of the arrow for two spaces or shift movements, corresponding to this adjustment.

Simultaneous with the downward movement of the bar 122 into the position shown in Fig. 8, bar 127 is carried downwardly due to its pivotal connection with bar 122. As the lever arm 130 is already positioned downwardly in the initial position, no movement takes place.

It is to be noted that in the initial position, the members 408, 409 and 410 are in the position shown by full lines in Fig. 16 and thus the setting plate 356 is in the position shown in Fig. 1. At the same time however pin 110 has released the lateral extension 164 of lever 160 so that it engages by a shoulder 282 over the pin 141 of the downwardly swung lever 142. If the key "2" is thereupon released, so that its cross extension 106 may be applied against the upper limiting edge 283 of the window-like recess 118 on tube 107, then at the same time the bar 122, through the pull of a spring 284, will follow the slide 98 since the bar 122 remains engaged with the lower end of the slide. On the return of the bar 122 it releases the pin 141, so that lever 142 can likewise follow under the pull of the spring 144. The pin 141 then carries the lever 160 somewhat upwardly, so that the lever 157, on which the lever 160 is mounted, is swung into the dotted position shown in Fig. 8. The lever 157 then releases the plate 152, so that it swings the pawl 154 against the ratchet wheel 121, in the position shown in Fig. 8 in dotted lines.

During the swinging movement of the plate 152, the bar 168 is at the same time carried by means of pin 167 to the left in Fig. 8, into the dotted position. In this movement of the bar 168, its end 370 contacts the pin 371 of the plate 372 and swings it into the position shown in Fig. 8. In this movement, finger 374 of the plate 372 has moved the rod 312 of the motor key 311 downwardly. Through the downward movement of rod 312, the circuit of motor 473 is closed by means of the members 314, 317, 318, 468 and 471. The coupling 480 and 482 is also connected, so that the shaft 323 is oscillated by means of the elements 484, 489, 492, 320 and 322.

In the counter-clockwise oscillation, in the direction of the arrow in Fig. 1, the pin 325 is swung upwardly, so that the type carrying bars 330 are released. These are then set up according to the values of the multiplicand 12738 contained in the carriage 305.

The oscillation of shaft 323 causes a corresponding oscillation of shaft 329 and this causes a reciprocation of setting plate 356. As this plate, as above stated, is in the lower position, as shown in Fig. 1, the plate 353 is not reversed or shifted in this movement. On the downward return movement of bars 330, the calculating mechanism gears 448 and 456 are swung in as described

above, so that the value contained in the carriage is transferred once to the calculating mechanism by such gears.

In the oscillation of the shaft 323, the link 402 swings the lever 405 in the direction of the arrow in Fig. 6 causing the pin 403 on the lever 405 to strike the extension 177 of the sliding bar 174 and move it to the right from the position shown in Fig. 6, against the traction of the spring 285 (Fig. 13) engaged therewith. In this movement of the bar 174 the shifting extension 184 contacts the ratchet shifting wheel 121, which in the present case is in the position shown in Fig. 8, and rotates it clockwise back for one step.

After the shaft 323 has returned to its initial position, after an oscillation, the multiplicand 12738 has been transferred once into the calculating mechanism. In the following second oscillation of the main shaft 323, the bar 174 is once more moved to the right so that the shifting extension 184 causes a second clockwise step rotation of the shifting wheel 121.

Inasmuch as the shifting wheel was moved previously counter-clockwise for two shift movements, thus at the end of the second oscillation of the shaft 323, the pin 287 on the shifting wheel 121 comes into range of a projection 290 provided on plate 152 and this plate 152 is swung into the initial position shown in Fig. 7.

By the return of the plate 152 into the initial position, the bar 168 is moved to the right back to its initial position and the pin 371 on the lever 372 is released so that the lever 372 may move to the position shown in Figs. 1 and 6. This breaks the electric motor circuit and disconnects the calculating mechanism drive. During the second oscillation of the main shaft 323 the multiplicand is carried a second time into the calculating mechanism.

It is to be noted that in the return movement of the bar 168 to the right, as shown in Fig. 6, the pawl 214 which, in the movement of the left of the bar 168, has passed in front of the shoulder 369, carries the slide plate 365 along in the direction of the arrow in Fig. 8. In this movement of the slide plate 365, the lever 207 connected therewith by the pin 206 is swung out in the direction of the arrow in Fig. 6. In this outward swinging of the lever 207, the lever 378 is swung to the right by the rod 376 and the spring 382 is placed under tension. Through this movement of the lever 378, the plate 381 is given the tendency to swing to the right (see Fig. 1). The lever 385 by means of pin 386 is applied against the extension 361 of the lever 359, which is thereby swung downwardly. This causes, however, by means of the associated rod 362 a movement of the carriage 305 for one decimal position in the direction of the arrow in Fig. 2.

It is also to be mentioned that, while the shaft 323 is oscillated the pin 398 on the lever 399 releases the corresponding arm of bellcrank lever 392, so that the bellcrank lever may swing under the pull of the spring 394 into the position shown in Fig. 8. When, at the end of the second oscillation of shaft 323, the pin 398 contacts with the corresponding arm of bellcrank lever 392, the latter is again swung into the position shown in Fig. 6. It then engages under the pin 396 of pawl 214, which is thereby raised into the position shown in Fig. 6. This causes the shoulder 369 of the slide 365 engaged by the pawl 214 to be released and the slide 365 can now snap back to the initial position shown in Fig. 6.

Entry of second decimal position of multiplier

The second decimal position of the multiplier is now to be entered. The "9" key of the multiplier keys 87 is depressed. It is to be noted that the lever 293 coordinated with the "9" key (Fig. 11) is swung so that its tongue-like extension 294 extends into the range of the key slide 88. If the key "9" (see Fig. 11) is depressed now it contacts with the tongue-like extension 294 of the corresponding lever 293. The key slide can thus not pass through the bent portion 262 but contacts with the corresponding tongue 284 and the bar 123 is forced downwardly. By means of the downward movement of the bar 123, the lever 135 is swung downwardly therewith by means of the bar 123, which, through the setting members 257—261, 243, 233, and 248, results in the shifting as shown in Fig. 11, in which at the downward end position of key "9" the lever 293 assumes the position shown in Fig. 11, and the tongue 294 coordinated with the key "9" is drawn out of the slot in the bent portion 262, while the tongue coordinated with the unpressed key "0" is swung into its cooperating slot.

In the downward movement of the bar 123, the lever 142 has been swung by means of the pin 141 and the pawl 111 is released. Tube 107 can thus pass to the left (Fig. 11) until the edge of the window-like recess 118 is applied against the cross extension 106 of the key slide. When the "9" key is pressed, the pawl 237 is raised out of notch 238 and through the corresponding spring 232 the U-shaped bar 228 is adjusted so that its window-like recesses 229 are aligned with the window-like recesses 118 of tube 107. The tube 107 may thus move to the left for one shift, as is apparent from the position of the shifting wheel 121 in Fig. 11. When the key is released, in the same manner as above described, the plate 152 will snap into the dotted line position of Fig. 8 and through the bar 168, the circuit of the motor is established and the calculating mechanism connected. The calculating mechanism then describes an oscillating movement of the main shaft 323, while the multiplicand 12738 is carried negatively, that is subtracted, in the second decimal position by the calculating mechanism gears 448 and 456.

It is to be noted that in the shifting of the rods 258 and 260, the lever 410 was moved into the dotted line position of Fig. 16, thus causing the setting plate 356 to be raised, so that its shoulder 357 is in front of the pin 354. At the beginning of the oscillating movement of the shaft 323 the plate 353 was carried into the dotted line position of Fig. 3 so that in the next movement of the calculating mechanism the reversing gears 456 are engaged with the racks 443.

During said oscillation of the main shaft 323, the bar 174 is moved once in the direction indicated in Fig. 6, in the manner above described, and the shifting wheel 121 describes a backward clockwise shifting movement, and is thereby carried to the initial position shown in Fig. 7. The plate 152 is again swung back by means of pin 267 and the bar 166 is simultaneously also drawn to the right to the position shown in Fig. 1, so that the motor 413 and the coupling 460 and 402 are disconnected through the member 372.

Simultaneously with the return movement of the bar 168 to the right another shift movement of the carriage 305 is brought about by means of the pawl 214 and the plate 365, as above described.

Entry of third decimal position of multiplier

The third decimal position of the multiplier is now to be entered. The "0" is carried into the multiplier mechanism by pressing the corresponding multiplier key 97. See Fig. 10. Since shortened multiplication was done in the second decimal position, the tongue 294 is in the range of the key slide 88 coordinated with the key "0". If the "0" key 97 is depressed the lower end of the key slide 98 first contacts with the tongue 294 and a descending movement of the bar 122 is initiated. On further descent to the end position in Fig. 10 the lower edge of slide 98 slides along the upper edge of the bar 122.

Since, before depressing the "0" key, the abutment 241 was in the lower position, the coordinated pawl 234 was raised from the notch 239 of the tube 107, so that on release of the tube it can pass into the position shown in Fig. 10, wherein the cross extension 106 on the key slide is applied against the corresponding edge of the recess 116. As a result of pawl 234 having been raised, the bar 227 is moved in tube 107 so that the edges of the recesses are aligned. Shifting wheel 121 can thus rotate for one step, as shown in Fig. 10.

Through the pressure on the "0" key, the bar 122 was carried downwardly and, by means of the bar 127, the lever 130 was shifted into the position of Fig. 10. This causes a shifting of the corresponding shift members 243 and 244 into the position according to Fig. 16. The lever 410 again passes into the position shown in Fig. 16 in full lines and the arm 418 has allowed the plate 356 to drop, so that its lower shoulder 358 is within range of the pin 355. During the following oscillation of shaft 323 the multiplicand 12738 is carried once, positively, into the calculating mechanism. During this oscillation (of the shaft 323), however, the shifting wheel, which previously was moved for one step from the initial position, is again returned to the initial position as shown in Fig. 7. Therefore the bar 166 is drawn back and the lever 372 released with a consequent breaking of the motor circuit and an uncoupling of the calculating mechanism. At the same time, however, by means of the pawl 214 and the plate 365, another shift step of the carriage 305 is brought about, so that the carriage is moved to the next higher decimal position.

Entry of fourth decimal position of multiplier

The fourth decimal position of the multiplier is now carried into the calculating machine by pressing the multiplier key 97 marked "6". On depressing the "6" key the lower end of the corresponding key slide 98 (Fig. 9) strikes against bar 123 and moves it downwardly. Tube 107 is thereby released in the manner previously described, so that it can pass to the left, until the coordinated cross extension 106 contacts with the corresponding edge of the window-like recess.

Since, on pressing the "0" key, the slides were shifted so that that designated 244 assumed the lower, and that designated 243, the upper position, the coordinated pawl 234, on depressing the "6" key, assumed the swung out position, so that its U-shaped bar 228 assumed the release position. The corresponding bar 228 could thus, through the traction of spring 232, be drawn back so that its window-like edges registered with the edges of the window-like recesses in tube 107. This means, however, as shown in Fig. 9, that

the tube 107 can move to such an extent that the shifting wheel 121 may describe four shift steps to bring pin 287 into action.

It is also to be noted that, by pressing on the bar 123 and actuating the bar 128, the levers 135 and 130 are carried into the position of Fig. 9. This causes the lever 410 to be shifted into the dotted line position of Fig. 16 through the action of the setting members 243 and 244. The setting plate 356 is thus swung by the arm 418 into the upper position in which its shoulder 357 comes in front of the pin 354.

In the consequent four oscillations of the main shaft 323 (corresponding to the four shifts of the wheel 121) the multiplicand 12738 is subtracted four times at the corresponding decimal position by the calculating mechanism gears 446 and 456. During the fourth oscillation of the shaft 323 the shifting wheel reaches its initial position as shown in Fig. 7 and the shift bar 168 is again moved to the right into its initial position. This, in turn, results in the disconnection of the electric motor 473 and the clutch 480, 482. In the return of bar 168, the carriage 305 is shifted a step by means of the pawl 214 and the plate 365.

Entry of fifth decimal position of multiplier

If, now, the multiplier key 87 marked "2" is pressed for the fifth decimal position of the multiplier, the position shown in Fig. 12 is assumed. As the pawl 234 coordinated with bar 227 is in the raised position, tube 107, in contrast to the position according to Fig. 8, can move to the left for three shift steps. The main shaft will, therefore, describe three oscillations before the bar 168 is moved to the right and the lever 372 is swung to disconnect the motor 473 and the coupling 480, 482. As the bar 127 is carried downwardly on depressing the multiplier key 87 marked "2," the levers 130 and 135 are shifted so that the lever 418 again assumes the position

shown in Fig. 16 in full lines. Arm 410 thus releases the setting plate 356, so that its shoulder 358 can come in front of pin 355. In the first rotary movement of main shaft 323 the calculating mechanism gears 446, 456 are carried into the plus or positive position, so that during the three oscillations of shaft 323 the multiplicand is carried three times into the corresponding next highest decimal position, positively.

The calculation is then terminated and the calculating mechanism contains the result

332,359,896

By actuating the keys 308 or 309 this result can be transferred to the type bars and printed on the strip 341.

The adding machine has thus done the following: first, the multiplicand 12738 was carried twice, positively, into the calculating mechanism. After a shift advance of the carriage 305 into the next higher decimal position the multiplicand was introduced once into the calculating mechanism subtractively. After a further shift movement of the carriage into the next higher decimal position the multiplicand was transferred positively into the calculating mechanism. This done, the carriage made a further shift movement into the next higher decimal position, in which the multiplicand was then introduced four times into the calculating mechanism. Finally, after another shift movement of carriage 305 into the next higher decimal position the multiplicand was added three times in the calculating mechanism. The calculation was thereby terminated and it was completed with eleven oscillations of the main shaft 323.

It is to be understood that the invention above described is not limited to "Astra" machines and may be embodied in other makes of adding machines and is capable of various modifications.

KARL BERTHOLD WILHELM KIEL.